

**PERFECT  
FILAMENT  
CONTROL  
FOR  
ALL  
TUBES**

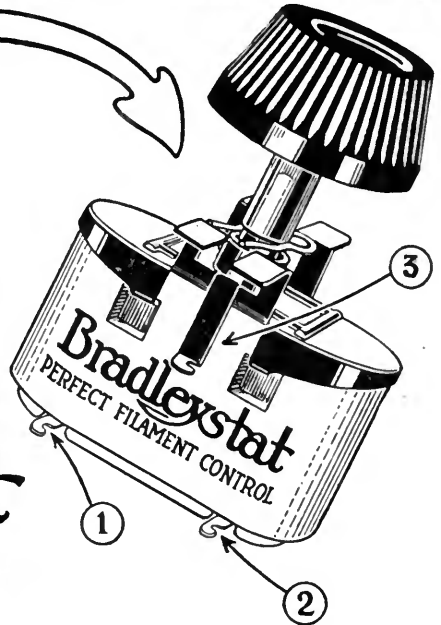

**Ask  
for the  
Universal  
Bradleystat  
With 3 Terminals**



**A Perplexing Problem Solved!**

**T**RY any tube in your radio set! It makes no difference what tube is used, the new universal Bradleystat with three terminals will give perfect filament control. A very simple change of connections and a remarkable range of control make this possible for the first time in radio history. Like former Bradleystat models, the new universal Bradleystat with three terminals is covered by the same iron-clad guarantee of perfect performance, noiseless control and quicker tuning that sold hundreds of thousands of Bradleystats during the past year.

Be prepared to try any new tube by replacing your present rheostats with the new universal Bradleystat. It is the last word in flexible and perfect control. It is backed by twenty years' experience with graphite disc rheostats. *Beware of imitations.* Avoid the use of inferior carbon powder rheostats. The name "Bradleystat" is embossed on container for your protection.

*Mail the coupon below for full information about the latest and most remarkable development in filament control. CLIP THE COUPON, NOW!*

ALLEN-PRADLEY CO. 278 Greenfield Ave. MILWAUKEE, WIS.

I am pleased to hear that the universal Bradleystat with three terminals has solved the perplexing problem of finding one rheostat for all tubes. This is good news. Please send me full information and explain how it is done

\_\_\_\_\_

\_\_\_\_\_

\_\_\_\_\_

- C-300
- C-301
- C-301A
- WD-11
- WD-12
- UV-200
- UV-201
- UV-201A
- UV-199

★ Tested and approved by RADIO BROADCAST ★

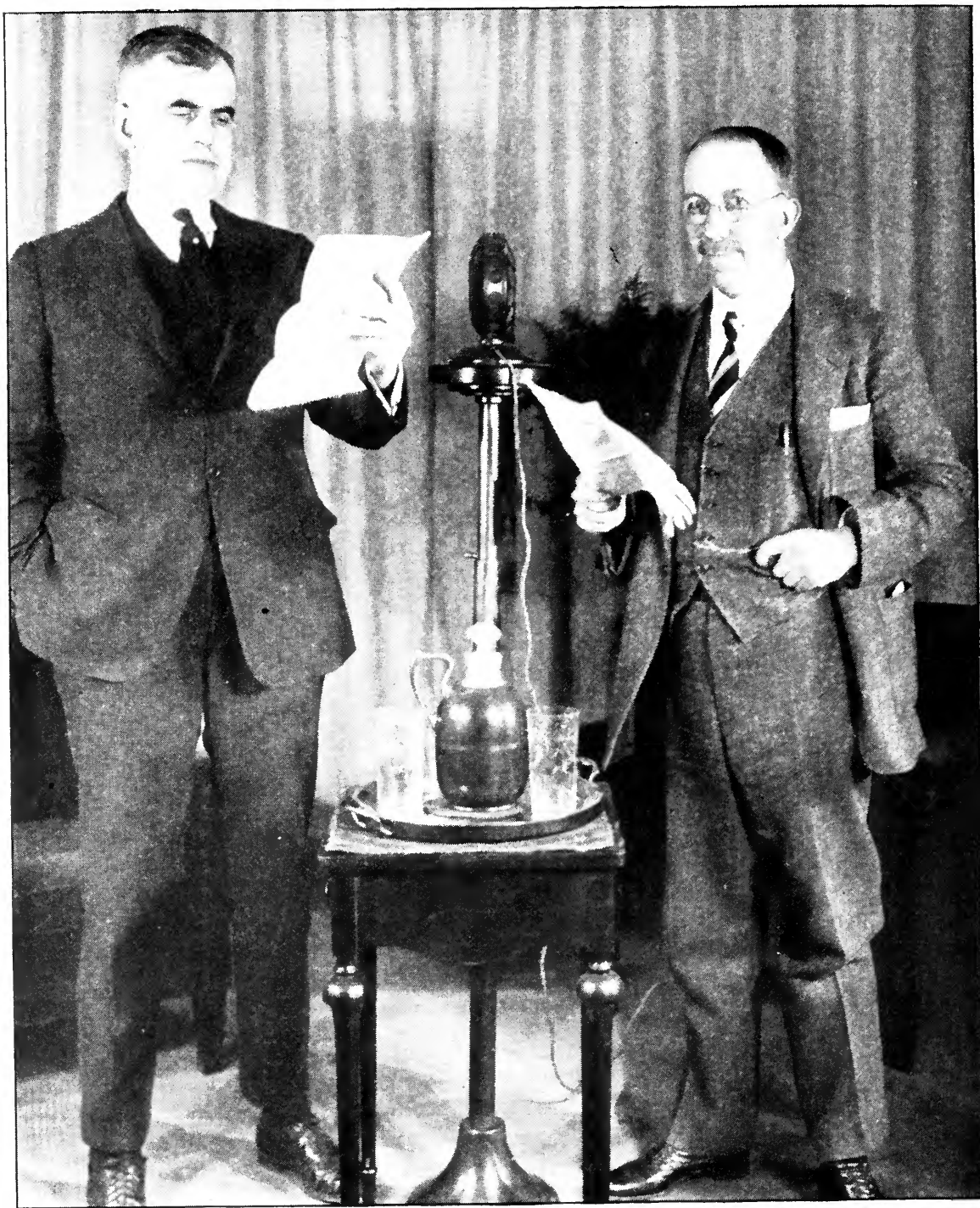

**"RESOLVED, THAT THE VOLSTEAD ACT SHOULD BE REPEALED"**

It is estimated that the debate between Wayne B. Wheeler (right), General Counsel of the Anti-Saloon League, and Ransom H. Gillett (left), General Counsel of the Association against the Prohibition Amendment, broadcasted on April 18th from WEA, New York, was heard by half a million people. This was the first time that two such leaders of opposing thought faced each other before the microphone on a subject of national interest and importance. At the finish of the debate, questions submitted by the audience were answered by the speakers. A poll of WEA's audience showed decisively that Mr. Wheeler won the debate, and that the personal preference of the radio audience on the question, "Should the Volstead Act be Repealed?" was 57% "No" and 43% "Yes"

# RADIO BROADCAST

Vol. 3 No. 3



July, 1923

## The March of Radio

### VOLSTEAD IN THE AIR

**I**N TRYING out the radio public to see what they like and what they don't like, WEAf, the well-known station of the American Telephone and Telegraph Company in New York, recently staged a debate on the liquor question: "Resolved, that the Volstead Act Should be Repealed."

This station is continually experimenting with broadcast material, not only with the idea of giving the public varied entertainment, but of enabling those responsible for its operation to gauge the extent of the public's interest in radio and to endeavor to gather reliable statistics as to what kind of programs the public wants. It is evidently in this way only that proper development of radio entertainment can be brought about—only by the tone of the correspondence received can the manager of the station judge of his success in catering to the public's desires. The American Telephone and Telegraph Company is spending many thousands of dollars a year to get the correct answer to the question, "What is the demand for broadcasting?"

The debate on the value of Mr. Volstead's activities was brought about by the Government Club, the President of this organization, Mrs. Geo. E. Owens, having charge of the program, introducing the speakers, and reading the questions sent in by the radio listeners. The public had been told to send in questions as the debate progressed and that their questions would be answered, as far as possible, by

the debaters. The debaters were Wayne B. Wheeler, general counsel of the Anti-saloon League of America, and Ransom H. Gillett, general counsel of the Association Against the Prohibition Amendment. That the question was a live one in which the listeners took an intense interest soon became evident as the questions poured in; only a small fraction of them could be answered in the time allotted.

As we listened to this debate, and pictured the invisible audience of possibly hundreds of thousands, the great utility of radio for political campaigning was once more driven home. The questions asked by the listeners showed thought—showed that the debaters were being closely followed in their arguments by their vast audience. When used by persons aspiring to governmental positions this method of presenting their virtues will prove of real value to those of worth, and should show up at the same time the hollow arguments and fallacies of the familiar political spell-binder. Not only is this scheme of contact between orator and public valuable to the public, allowing them to analyze what the speaker is trying to "put over," but it also has certain advantages for the speaker. It makes him condense his arguments to such a degree that he cannot well remain ignorant of the weak spots and possible fallacies in his speech and it furthermore allows him to proceed uninterrupted to the end. His would-be hecklers must remain silent until he chooses to answer their questions.

### More Injunctions for the Broadcasters

WE NOTED some time ago the action of the American Society of Composers, Authors, and Publishers, in calling on broadcasting stations either to pay royalties for broadcasting music or plays put out under the copyright of its members, or to cease broadcasting such material. We mentioned at the time that the stand of the jazz writers seemed to be somewhat unreasonable in that, whatever their legal rights might be, given to them by our copyright statutes, most of the broadcasting stations were operating as experiments only and were undoubtedly carried by their owners at a considerable loss. When a station can be shown to be on a paying basis then it seems proper for the music writers to collect as their share of the proceeds as much as seems reasonable, but to insist on large royalties while the game is in the experimental stage seems very much like killing the goose which might, some day, lay golden eggs for them.

Our ideas along this line are confirmed by the recent decision of the management of WJZ, the Radio Corporation station at Newark, not to broadcast any more material copyrighted by the members of the complaining society. Thus it seems that the members are certainly going to collect no royalties from the Radio Corporation and it seems, furthermore, that this cor-

poration is one of the very few companies which might show a real, substantial profit as a result of its radio activities.

This company sells a great many receiving sets, realizing no doubt a considerable profit on them, furthermore in the manufacture and sale of tubes the average buyer believes there must be a considerable profit for some one. According to a recent communication from the President of the Radio Corporation, General James G. Harbord, one tube factory alone of the Radio Corporation was turning out 5,000 tubes a day and expected soon to put on the market 10,000 tubes a day. His company had been severely criticised regarding the sudden disappearance from the market of the WD-11 dry-cell tube of the Westinghouse branch of the Radio Corporation; some even went so far as to accuse the company of actually suppressing the sale of these tubes, so that complete sets, in which the tubes were used, could be unloaded on the public. In answering the charge the General made the statement given above, that they would soon be making 10,000 WD-11's a day. If we add to this number a proportionate figure for those made by the General Electric Company, it would seem that the public was buying tubes at the rate of more than a hundred thousand a week!

Is it? If so, it would seem that this company might possibly figure quite a profit from its radio business, but with the American Telephone and Telegraph Company, which as a result of an agreement with the Radio Corporation, sells practically no radio receiving sets or tubes (compared to the numbers estimated above), the situation is different. Their activities in the radio broadcasting field have proved so far a rather expensive proposition, yet they have come to some kind of an agreement with the Society of Composers, Authors, and Publishers, and tell their audience so every time they broadcast—tell it in phraseology which sounds as though it had been specified by counsel for the musicians. We



GOB FANS ON THE U. S. S. "MARYLAND"

Many home-made sets are turned out by radio enthusiasts in the Navy. This particular quartet—Arthur Johnson, Thomas Frank, Frank June, and Alvin Munne—are known as the "movie gang," as they operate the movies on the *Maryland*

think the public is rather "fed up" with this society and would enjoy some music without being informed of the copyrighters' existence.

But it seems that WEAFF'S compromise with the S. C. A. P. only leads to more of the same kind of thing; in their efforts to give the public a chance to see how they might enjoy a musical play via radio they arranged to broadcast one directly from a New York theater. This

scheme at once called forth an announcement from Mr. Arthur Hammerstein, in behalf of another society, this time the Producing Managers' Association, in which it is declared that "on behalf of the Producing Managers' Association I wish it to be understood that no music of any opera, musical comedy, or musical play produced by these managers will be permitted to be broadcasted by radio or otherwise without the consent of the Producing Managers' Association. We give notice now that we shall hold to strict accountability any one who shall attempt to produce or broadcast any of our music or any of our works . . . in addition to which we shall attempt to hold, if it is found possible, any violators of our rights under the copyright laws of the country."

So it seems that the path of the broadcast station manager is beset with difficulties—wherever he turns for material he finds the counsel of some body or other confronting him, with bills for royalties in one hand and an injunction in the other. In the meantime the public, the real beneficiaries, get it all for nothing.

### The Electron and its Discoverer

ANY ONE who has read even an elementary text on radio has at least a speaking acquaintance with the electron, the minute charge of negative electricity of which there are varying numbers associated with each atom, and to the arrangement and behavior of which is due the apparently complex system of chemical elements. In what way does hydrogen, our lightest element, differ from mercury, one of the heaviest? Only in the number



SIR ARTHUR CONAN DOYLE AND LADY DOYLE AT WJZ

While Lady Doyle broadcasted her views on spiritualism from the Radio Corporation station at Newark, Sir Arthur, known to everyone as the creator of "Sherlock Holmes" and lately come into public attention as one of the foremost investigators in the field of spiritualism, marveled at the potentialities of radio telephony

and arrangement of the electrons around the positive nucleus of the atom. The number of positive charges increases as does the number of electrons with increasing mass of the atom, but the whole behavior and chemical qualities of the various substances seem to be due entirely to the arrangement of the electrons only. In what way does oxygen, the life-sustaining gas, differ from chlorine, the death-dealing gas? Only by the number and arrangement of the electrons in the atom. Can one element be changed to another? By shooting off electrons and positive charges from their atoms the radio-active substances are continually changing from one chemical element to another. Sir Ernest Rutherford has recently shown it possible to "hit" a complex atom with sufficient force to knock it to pieces, the pieces in this case being atoms of other substances. Besides being the active agent in the field of radio, the electron, and its arrangement in the atom, give us the various colors of light, our X-rays, etc.

These same electrons serve to pull trolley cars and subway trains. The electrons in the copper wires of the armature, moving with respect to the electrons in the field windings and magnetic poles of the motor are able, by their concerted action, to develop sufficient force to haul a long train at high speed. It is this same electron which evaporates from the filament of the vacuum tube, and attracted by the positive plate, makes possible the conduction of a current through what is otherwise a vacuum. The electrons oscillating up and down in the antenna of the transmitting station send out waves over their electric fields,

which waves are able to set up corresponding oscillations in the receiving antenna, and thus permit radio communication.

Because of the important part played by the electron in radio, it is fitting to call your attention to the visit to this country of Sir J. J. Thompson of Cambridge University, England, the discoverer of the electron. He has just finished a course of five lectures before the Franklin Institute of Philadelphia, at which all the lectures had to do with some phase of electron activity. Using that keen vision and imagination with which every real scientist must be endowed, he called attention in one of his lectures to the action of an electron held fast to the positive nucleus of the atom, not able to move around as are the electrons which by their motion give the electric current. These rigidly held electrons have certain definite arrangements in which they must fit to make a certain element; if by some means one of these electrons is disturbed from its normal position in the atom it will at once endeavor to fall back into its proper position. As it regains

its proper place in the atom it generally oscillates back and forth about this position, as it "settles down." While the electron is thus oscillating around its proper place in the atom it sends out waves on its electric field just as do the electrons in the antenna of the broadcasting station, but in the cases analyzed by the lecturer the frequency of the vibrations is millions of times as great as the frequencies used in radio transmission; these excessively high frequency waves are the waves of ordinary light or in the case of those much shorter than light waves, X-rays. Thus, says the lecturer, every atom, having its electrons disturbed from their normal positions, acts as a transmitting antenna, while they are settling back into place.

Moreover, different atoms, under like excitation, send out different wavelengths just as different transmitting stations do. Thus an atom of hydrogen, with vibrating electrons, will send off entirely different wavelengths from those of an atom of oxygen or any other chemical element. Whereas our transmitting



"THIS IS STATION BG4"—OF THE 101ST SIGNAL BATTALION, N. Y. N. G.

Located in Herald Square, New York, this field station, type SCR 67A, treats passers-by with music and speech from local broadcasting stations, and also sends out recruiting talks on 200 meters. The receiving apparatus consists of detector and six stages of amplification, affording plenty of "kick" for the loud speaker

antennas send off only one wave, however (if the effect of modulation on frequency is neglected), each atom sends off many waves, but no two atoms, of different substances, send off waves of the same length, so that no interference is caused between the different elements. To detect these different wavelengths the physicist uses a spectrograph instead of a radio receiver; by the reading on his spectrograph he can tell exactly what "atomic broadcasting stations" are operating and thus recognize the presence of different atoms. By this means the physicist knows what substances are on the hot stars, even though they are millions of millions of miles away—a record for long distance reception never to be equalled by the ordinary broadcasting receiver.

Sir Joseph's picture of these "atomic broadcasting stations," transmitting their characteristic waves over distances inconceivably great compared to terrestrial distances, with wavelengths so faithfully maintained at the values assigned to them by Nature that our best measuring instruments, thousands of times as precise as any radio measuring instruments, cannot even detect any departure whatever, cannot but serve as a stimulus and inspiration to our research workers, ever seeking to expand and improve the radio art.

### Wavelength or Frequency?

**A** CHANGE in radio nomenclature is now being advocated by radio engineers and others interested in radio development, which, if adopted, will put into the discard the familiar term "wavelength." In place of this term, which really serves to identify the



SIR JOSEPH THOMSON, DISCOVERER OF THE ELECTRON

On his recent visit to this country, he witnessed the progress which American engineers had made with his theory of electrons, upon which the present development of long-distance radio communication is largely based. His investigations along this line took Sir Joseph Thomson ten years

number of cycles per second of the alternating current at the transmitting station, will be substituted the more logical and reasonable word, frequency, measured in cycles per second.

Radio is nothing but a special branch of communication engineering, itself an important sub-division of the general field of electrical engineering; and as such its language must naturally conform to that of electrical engineering as a whole. Certain specific features of radio communication, being peculiar to radio, and used only by radio engineers and experimenters, may be named in accordance with the

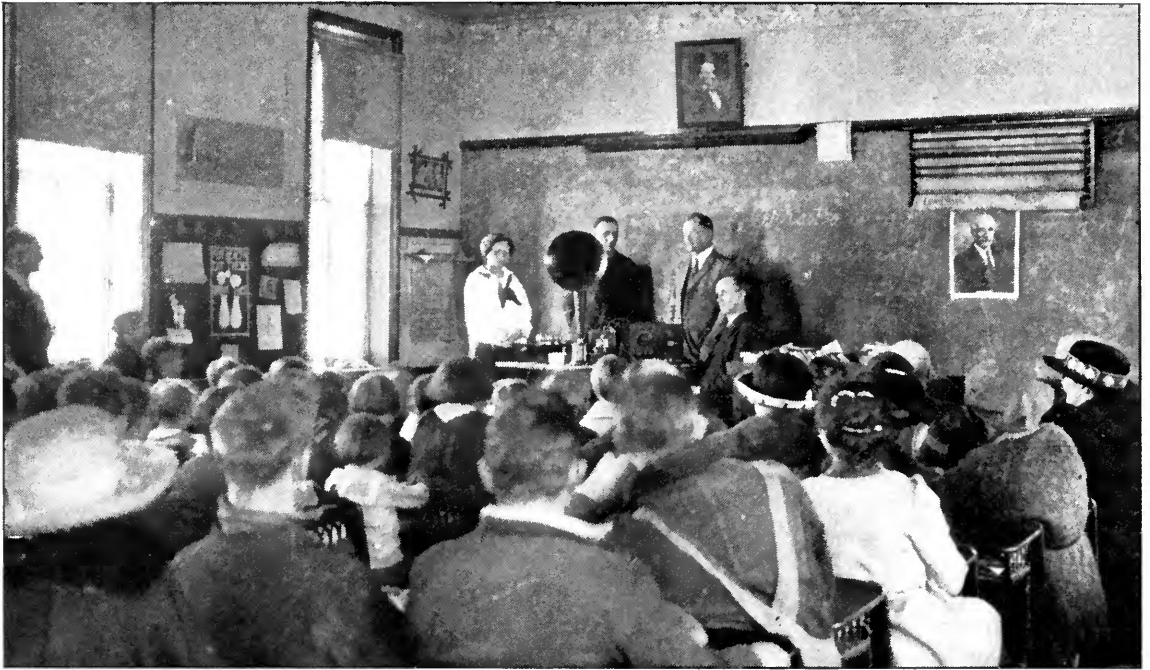

LISTENING TO AN ADDRESS BY GOVERNOR PINCHOT IN ORRSTOWN, PA.

In this rural community, young and old gather in the little school-house to hear the broadcasts received on the set owned and operated by Miss Hannah H. Kieffer, Director of Rural Education in the Cumberland Valley. This receiver, with the power amplifier, is used in twelve different community centres, and has brought in stations from Iowa to Texas and from Canada to Cuba

judgment of those responsible for coining the new words and expressions, but in so far as radio uses ideas and methods in use in other branches of engineering, which have already been named and defined, the nomenclature must be consistent with that already adopted.

It is very easy to see how radio has developed its own language; when Marconi and the other pioneers started to talk and write about their work it was not at all evident that they were engaged in a natural sub-division of engineering. It undoubtedly seemed to them an entirely new art and as such to demand new words and expressions. But as we have studied and experimented in radio, discovered its laws, and found them to be in agreement with those of other branches of electrical engineering, it has become ever more evident that here is simply an addition to the general field of communication engineering and as such it must incline in its language toward that already in vogue among communication engineers.

That the language of radio has changed to a great extent even during its short life of a quarter of a century becomes evident to one

reading the early writings. We wonder how many of our readers know what a "jigger" is and does; to Marconi it was an extremely important piece of apparatus. Does any one nowadays use one of Marconi's "X-stoppers"? Fifteen years ago, Fleming invented the very useful "cymometer", yet we do not often hear it mentioned. Fessenden, in his early and important contributions to the art, employed a "barretter" which he found very sensitive and reliable, compared to other similar apparatus, and Count von Arco's "syntonizer" seemed like a piece of radio equipment destined to become known to every one. We suspect that a large proportion of our readers hardly know what a coherer is, yet it was but a few years ago that every radio worker was endeavoring to improve it. The radio nomenclature of to-day does not know these words of only a few years ago, so it is not at all unlikely that many of our present terms may likewise disappear in a few more years.

One of the most important characteristics of a radio signal is its frequency, that is, the frequency of the alternating current in the antenna of the transmitting station. In the



early days this was known only approximately, but it was always many hundreds of thousands of cycles per second, if not several millions. As the early experimenters, familiar with the electromagnetic theory of Clerk Maxwell, and the experimental verification of the same by Heinrich Hertz, pictured the electromagnetic waves shaken off from their antennas and traveling away in all directions with the velocity of light, it was natural for them to think of wavelengths, as well as frequency, and as the wavelengths, in meters, were generally a few hundreds only, and the frequency hundreds of thousands or more, it naturally became the practice to speak of wavelength in meters rather than of frequency in cycles per second.

As long distance radio developed, and the longer waves proved more suitable than the shorter ones, the frequencies used became lower and lower; thus a 15,000-meter wave used for transatlantic communication, requires in the antenna a current of only 20,000 cycles per second and this is getting well down to the frequencies used every day by the telephone engineer. It seems then, that from this viewpoint alone, it would be advisable to conform to engineering usage and speak of cycles instead of wavelength, unless some serious disadvantage should arise therefrom. Instead of being disadvantageous, however, it will be pointed out later that a marked advantage accrues to the radio engineer by thinking in terms of cycles instead of wavelength.

It will be remarked that the frequencies of the currents used in broadcasting are always several hundred thousand per second, so that apparently inconveniently large numbers would have to be used, such as seven hundred and fifty thousand cycles per second, which is evidently more troublesome than to say a wavelength of four hundred meters. But the term seven hundred and fifty thousand cycles per second will be abbreviated to seven hundred and fifty kilo-cycles; electrical engineers have found it un-

necessary to retain the "per second" part of the term as this is always understood, and the idea of "thousand" is obtained from the prefix "kilo". The engineer interested in transmission lines always speaks of "so many kilo-volts" instead of speaking of thousands of volts. So the four hundred meter wave signal may soon become a seven hundred and fifty kilo-cycle signal and the three hundred meter wave a one thousand kilo-cycle signal, etc.

The advantage of speaking in kilo-cycles, besides putting radio in conformity with the rest of electrical engineering nomenclature, arises from the ideas of "wave bands" used in radio telephony. There the kilo-cycle shows itself much more useful in conveying information than the term wavelength. For the ordinary radio telephone channel there is required a band of frequencies about ten thousand cycles wide, on each side of the carrier frequency. Thus a four hundred meter broadcasting station, using the ordinary method of modulation, requires the exclusive use of frequencies from seven hundred forty to seven hundred sixty kilo-cycles, the carrier frequency being seven hundred fifty kilo-cycles. A neighboring station, sending with a carrier of seven hundred twenty-five kilo-cycles, would require for its exclusive use all frequencies between



AN ENGLISHMAN TELLS THE BEAR FACTS  
This diminutive British subject is rebroadcasting to his attentive companion the story of the Three Bears

seven hundred fifteen and seven hundred thirty-five kilo-cycles. With a good receiving set there would be no interference between these two stations, although it would not be advisable to use carrier frequencies so close together for neighboring stations, because the crystal sets, of which there are a good many in use, would be bothered by interference.

Now this frequency band, carrier frequency plus and minus ten thousand, is required *no matter what the wavelength of the carrier may be*, so that in calculating the number of radio telephone channels available in a certain wavelength range the engineer has to change the wavelengths over to frequencies anyway. Moreover when this is done it is much easier to see at once the number of channels available in a given assigned range than it is if the same range is given in wavelengths. *Thus if broadcasting is given a wavelength range of from 220 meters to 550 meters, and amateurs are assigned the 150 to 220 meter band, it seems as though they*

*were getting squeezed into a pretty narrow region, but this is really not the case.* The assignment would give to broadcasting from 545 kilo-cycles to 1360 kilo-cycles, a band of 815 kilo-cycles in which about twenty channels are available. The assignment to the amateur, although apparently much narrower than this actually gives to him a frequency band 640 kilo-cycles wide, almost as many channels thus being available to the amateur as to the wider wavelength assignment for broadcasting. This increase in the number of channels in a given wavelength band as the band moves into the shorter waves is not apparent when speaking in terms of wavelength, but appears at once when the frequency of the current is used to designate the signal instead of the wavelength.

From the foregoing analysis, the advantage of kilo-cycles over wavelength is evident and when it is further remembered that all the instruments used for making radio measurements are really frequency-measuring instru-

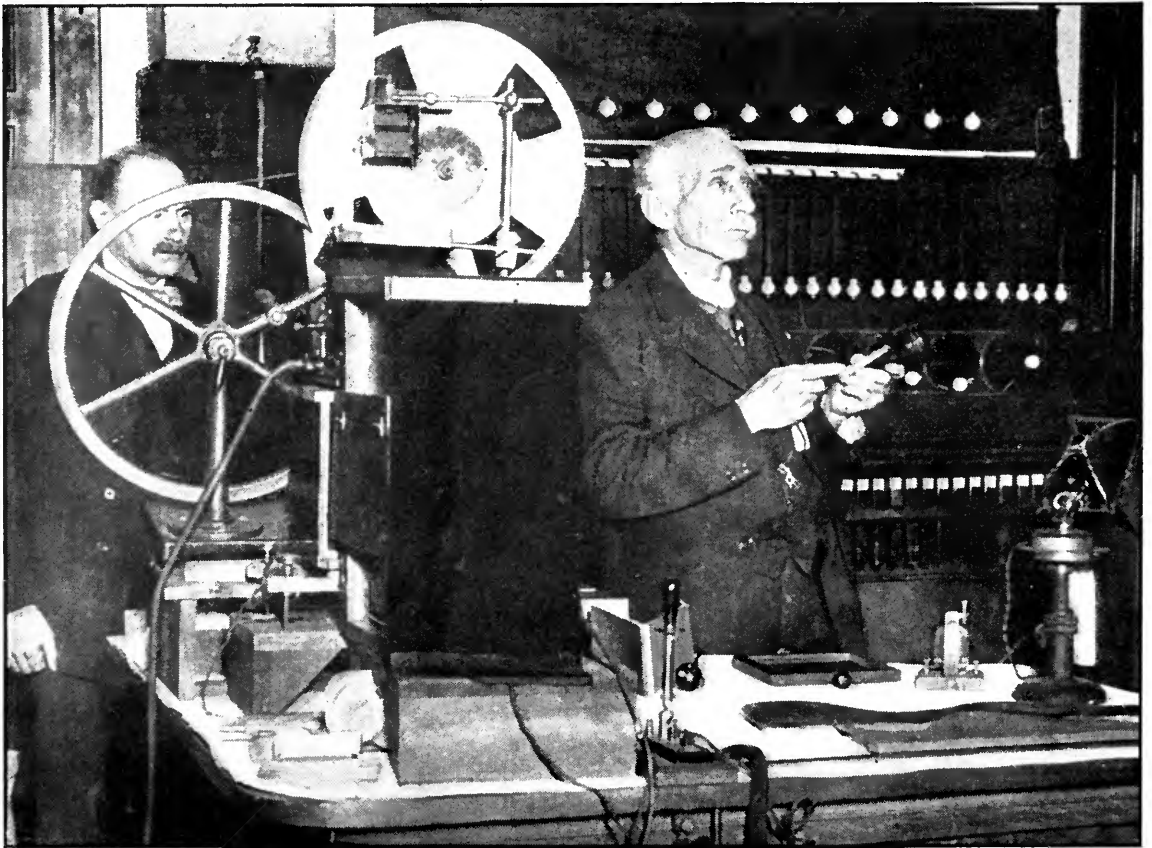

PROFESSOR J. A. FLEMING, F. R. S.

The inventor of the Fleming valve explaining the action of the telephone receiver at one of the lectures he holds for children at the Royal Institution



PUBLIC SCHOOL STUDENTS BROADCASTING THEIR PRIZE COMPOSITIONS

Violet Miller, age 12, of School No. 77, Ridgewood, Long Island, is "on" at WHN, while other budding writers await their turn. School No. 77 is perhaps the first to hold a children's radio forum, an institution which not only stimulates a great interest in the writing of compositions, but gives the children excellent practice in public-speaking

ments rather than wavelength meters as appears from the name "wave meter", and when it is further appreciated that waves do not have their specified length except when they are traveling through free space where there is no absorption, the decision of the radio engineers to use kilo-cycles instead of wavelength is seen to be reasonable and justifiable. Standard works on radio, and technical radio magazines will, for some time at least, print the kilo-cycles per second and wavelength in meters side by side. So it is well to get yourself accustomed to thinking of a station in terms of its kilo-cycles, obtained by dividing three hundred thousand by the wavelength in meters.

### The Possibility of Re-Broadcasting

**I**T IS evident to any one who thinks much about the question that in the final solution of the broadcasting problem a given program must be made to reach as large an audience as possible; as the programs of the

broadcasting stations improve, this fact will become increasingly apparent. For example, if an opera is being broadcasted from the Metropolitan Opera House in New York, the artists may be the finest in the world; why then should people in other sections of the country who enjoy opera, have to listen to some mediocre program from a local station? Of course, entirely apart from radio, this is actually the case to-day; we can't all go to the best opera and so we have to content ourselves with something less expensive and less artistic. But right here lies the great promise of radio—it need cost but little more to broadcast to a million listeners than to a thousand, so that the very best programmes should be available to every one.

Some enthusiasts will of course say, "Why worry about the situation? We listen to New York programs every night even though we are more than a thousand miles away." But for every such listener there are a hundred others, potential or actual listeners, who do not re-



SOLDERING TRANSFORMER LEADS—A DELICATE JOB

There are more than one hundred distinct parts used in each of these audio-frequency transformers. No. 40 enameled wire, thinner than a human hair, is used and the task of making uniformly neat soldering jobs with wire as fine as this would be difficult for most people. Not so for Miss Gay Garrity, however

ceive over such distances. The majority will probably always be in this class. Expensive receiving sets, great selectivity and difficult manipulation, are not the factors which make for the popularization of radio, and most of these are required for reliable long distance reception.

The question then arises, How is the multitude to get in contact with the good stations? Two possibilities are being tried out and both of them are likely to be in service before long. The program can be relayed to the various broadcasting stations located throughout the country by either radio or wire. Station KDKA has for some time past been sending out its programs for re-broadcasting in other cities, the transmission between the two stations being carried out on a 100-meter wave. This 100-meter signal is used to actuate the modulator of the second broadcasting station, in Cleveland for example, which then sends out the program on 360 meters. This scheme requires the very best kind of receiving set at the second station in order that the signal may not be unreasonably distorted while being received and amplified for its second transmission.

The second scheme, which seems to us more reasonable, less likely to either receive or give interference, is to send the signal from the first

broadcasting station to the others in the form of audio-frequency currents, over wires. This will undoubtedly be the method of attack of the American Telephone and Telegraph Company as their engineers are experts on speech transmission over wires, and they can carry speech currents over wires almost any distance, with as little distortion as the case may demand. They understand the factors involved sufficiently well to predict, even before a line is put into operation, how good the speech will be; if the amount of permissible distortion is specified, they can design a line and terminal apparatus which will meet the specifications.

In other words here is a problem which can be solved any time the money is available: Telephone transmission is frequently very poor, as every one knows, but the ordinary transmission does not show, by any means, what the engineering staff could do if occasion demanded better, and if the funds were available.

In this scheme, therefore, all broadcasting stations will be connected to a network of telephone lines and cables, and the same audio-frequency signal will modulate all the radio transmitters simultaneously. This scheme does not use up any extra ether channels and should be much less subject to atmospheric and other disturbances than is the radio transmission. Moreover, disturbances on a wire line can generally be eliminated by certain engineering tricks, if the importance of the transmission justifies the expense, whereas but little progress has been made in eliminating static disturbances from the ether channels.

It seems to us that the future of broadcasting is intimately connected with the establishment of a wire network covering the country and connected to the best broadcasting station in a given locality, this wire network to be of the highest quality that the telephone engineer—who has had years of experience in this sort of thing—knows how to build.

## Weather Forecasts

WITH the idea of increasing the utility of the Weather Bureau service, a new broadcasting schedule has been recently put into effect. Every day of the year there will be sent out from the Arlington Naval Radio Station (NAA), on a wavelength of 710 meters, radio telephone weather forecasts and warnings for all the Eastern part of the United States.

In addition to these services, at 10.05 A. M. and 10.05 P. M., an additional forecast will be sent out, at 3.45 P. M., daily except Sundays and holidays, and also on Wednesdays (at 7.45 P. M.) during the growing season, March 15 to Nov. 30, advice will be sent out for farmers and others interested, summing up the effect of the weather for the past week on the progress of the crops.

A feature of this service which provides for dissemination of the weather forecasts immediately after they are issued, is that the announcements are made directly from the Weather Bureau Office in Washington, which is connected by telephone with the transmitting apparatus located at Arlington. The bulletin giving us this information requests that listeners send in suggestions to the Chief of the Weather Bureau, Washington, D. C., stating which service is of most use to them, how the transmission is received, as well as any suggestions regarding the possible improvement in this new branch of government activity.

## An Old Radio Company Changes Hands

ACCORDING to a recent announcement of Mr. Charles Gilbert, President of the De Forest Radio Telephone and Telegraph Company, the control of this company has passed into the hands of certain automobile manufacturers, including E. T. Jewett, of the Paige Motor Car Company, some of the financiers having large interests in the automobile industry, and William H. Priess, the latter having a patent on a certain reflex circuit at present used in some of the De Forest sets. The re-organization will place at the disposal of the company sufficient funds to permit that expansion which the ever-increasing interest in radio receiving seems to warrant. Dr. De Forest has been retained by the new company as consulting engineer, his services being engaged for a period of ten years together with

rights relating to patents he may obtain during that period.

The De Forest company is anticipating a considerable increase in its tube plant. According to Mr. Gilbert, the present plant has a capacity of 1200 tubes a day, but it is expected to increase the number of men employed there from 300 to 600 and so increase the tube output to 2400 a day.

Certain subsidiary De Forest companies, notably those primarily interested in research and development, will continue their work as at present, but the result of their work will undoubtedly be placed at the disposal of the larger company. The phono-film, De Forest's invention in the field of talking movies, is not affected by the transfer as this development has already been taken over by a company formed especially for the purpose. Still another De Forest enterprise, the De Forest Patent Holding Corporation, is exempt from the new agreement, its control remaining as at present.

## An Opportunity

PEOPLE away on a summer vacation are especially susceptible to new ideas, their old prejudices have been left at home and they are quite ready to try anything that looks interesting. They are easily "sold," as witness the high hotel rates for mediocre accommodations and the excessive prices often charged at the novelty stores with which the average summer resort is so richly endowed.

Now, if the Radio Dealers' Association would put into the summer hotel one of their best receiving sets, with the best loud speaker obtainable, we believe many people would become radio converts. Many times the evenings at the smaller resorts are quite dull, and we are sure that a good receiving set would be an attraction which could do real service. It would pay the dealers to install these sets in the hotel for nothing, and maintain them for nothing; the people at the resorts are the kind that have sufficient money to invest in a good receiving set, and they will be excellent "prospects" if the demonstrations are good enough to create the right impression.

There are receiving sets and loud speakers which reproduce music better than the best phonograph.

This looks like a real opportunity to increase the popularity of radio, and we hope the dealers will seize it.

J. H. M.

# Making Radio Your Business

By CARL DREHER

Engineer, Radio Corporation of America

AFTER extended observation I am convinced that the rising generation intends to go into professional radio *en masse*. Not only the rising generation, but also many of the generation long since risen. What are the opportunities, they want to know? What sort of jobs are to be had or will be available, what qualifications are necessary, what personal qualities are desirable? Can one become rich as fast as Coal-Oil Johnny, or richer and faster? Shall we train little Oswald to be a radio engineer, or do you think he will be happier as a lard salesman? Will Mr. X, who lost everything he had during the late radio boom, ever regain it? Was it his fault that he went under, or was it Fate? Do all wireless operators rise to \$10,000-a-year jobs? And so on.

Not all of these questions can be readily answered, but it may be useful to attempt the formulation of a list, more or less complete, of the various positions which the individual vaguely known as a "radio man" may fill, and the particular type of character which fits best into each place. In some cases this is a matter of opinion, and while the writer's ideas are based on acquaintance with and observation of a considerable number of radio professionals in active practice, he does not wish to lay down dogmatic rules, nor to have his conclusions swallowed uncritically. It is obvious, however, that the engineer in charge of a broadcasting station, for example, should know a scherzo from a Maltese cat, possess some social ability, and not chew tobacco, while the wireless operator of an oil tanker need not shave more than once in a fortnight, need know nothing about music, and may chew tobacco or even loco weed without hindrance. A particular variety of character make-up, that is, is required for each of these positions, in addition to the difference in technical qualifications.

A very common means of breaking into professional radio is by the operating route. Professional operators are recruited largely from the ranks of the amateurs. Many boys of high school age learn the rudiments of radio

theory at home, running their own sets, then go to a school for a period of about six months, to be taught the somewhat different methods of handling commercial equipment and dispatching traffic. If they qualify for the second grade operator's license they may then be assigned to a ship as junior operators. This is a sort of apprenticeship, for while the second operator stands regular watches, in case of emergency, or if he gets into trouble, he can always rout out the senior radio man, provided the latter is of a not too irascible temper. In time, usually about a year after he thinks that he knows more than the senior operator, the junior may be promoted to the first position on board some other ship, and then, after some years more of marine service, he may be in line for a job at a land station.

## ABOUT GOING TO SEA

THE advantages of the marine operator's life are that he gets to see the world and the ways of other people than those of his native Main Street; that he can save considerable money if he is so inclined; that his migratory existence usually preserves him from getting married too early, and that he has an opportunity to study and to learn the insides, not only of ship-to-shore radio, but the shipping industry in general. In regard to saving money, the average senior operator is paid in the neighborhood of \$100 a month at the present time, and a junior about \$70, plus his lodging and food aboard ship. It is not at all difficult for an operator to lay away \$40-\$70 a month, if he is not too much attracted by the bright lights on his periods of shore leave, and thus in the course of a few years he may amass a capital of several thousand dollars and be in a position to start a small business on shore. The disadvantages are that the hours are irregular and involve night work, and some men find this schedule unhygienic, although the health of the general run of ship operators is probably as good as that of men in other vocations; and that in many cases the man tends to become lazy and to lose his ambition. Ship jobs are of all kinds—on the large transoceanic

liners the telegraphers work almost as hard as the Morse operators on bonus wires ashore, and in fact high speed automatic equipment is being installed on some vessels in this class. On other ships the work is very slack; only a few messages a day are handled, and if the operators are naturally inclined to follow the line of least resistance, such positions are demoralizing.

While some of the foremost executives in radio to-day received their start as operators, it is also true that a man may be industrious, and be an extraordinary operator, and yet show little aptitude for any other position. In such a case he frequently gets into high-power reception, where the particular coördination of ear, eye, and hand at which he has become adept will stand him in good stead. The pay of such men runs about level with that of skilled landline telegraphers in brokers' offices and the like, about \$180 a month, with often a chance to earn more by working overtime.

This is for really fast men who can take 35 words a minute. Contrary to the general impression, a man may be an excellent operator and know little of the mechanics or theory of radio. As in the case of other fields, the work is tending to become more and more specialized, and just as many engineers scarcely know the Continental code, so operators may be found who have less acquaintance with the engineering aspects of the art than some of the enthusiastic laymen in the broadcast reception ranks.

A skilled operator who shows comprehension of the technique of handling traffic—routing of messages, proper coördination with foreign stations, and the like, and who displays some executive ability, may graduate into the ranks of supervisors, chief operators, and superintendents of stations. In these positions a

man must possess technical qualifications enough to enable him to cooperate with engineers, he must know how to keep traffic moving as fast as is consistent with accuracy under various conditions, and he must be familiar with the ordinary methods and principles of business practice. All this requires ability which comes only with years of observation and experience.

Not only is it necessary to know radio, but experience in other lines of communication is also very desirable. The majority of the traffic executives in radio to-day are ex-cable and ex-telegraph men. They know how to cooperate with the older methods of communication, and how to compete with them when expedient. They are not likely to overlook tricks of the wire trade which may be adapted readily to ether communication. The development of radio has in many respects paralleled the growth of wire telegraphy, in, for example, high-speed automatic methods, and

the history of radio invention is in part a process of adaption from cable and wire technique with, of course, many innovations and novel expedients. Likewise the men at the very top of radio communication, particularly in its high-power international aspects, are largely former executives of wire telegraph companies. Accordingly, if a man wants to become a real expert in radio telegraphy, it might be good advice to tell him to start with a cable company, just as a few years of telephone experience are a sizable asset for a specialist in radio broadcasting.

#### THE TRAFFIC MAN

THE traffic or operating man must always be prepared to think and act quickly, as an inherent requisite in his field. He has under his charge expensive machinery and elab-

Summer is with us again. Schools and colleges are "letting out" until next September; and many a young fellow is looking for a job of a kind that will be at once a business training, a vacation (at least in the sense of being a change from the winter's work), and a source of income. Comparatively few young men have a strong natural inclination toward one particular kind of work. Often, it is by the merest chance—a scrap of information that appeals to the imagination, a lack of interest in certain other fields, or some unaccountable and illogical prejudice—which lands a fellow in a job in which he is destined to make a distinct success.

A boy's hobby often leads to a man's business. How many young radio enthusiasts of to-day will be in one way or another connected with the radio game when they grow older? Thousands—that is certain. For them, and for other thousands who may have only a vague idea, or none at all, that their life work may be concerned with radio, this article of Mr. Dreher's will have a strong appeal.—THE EDITOR.

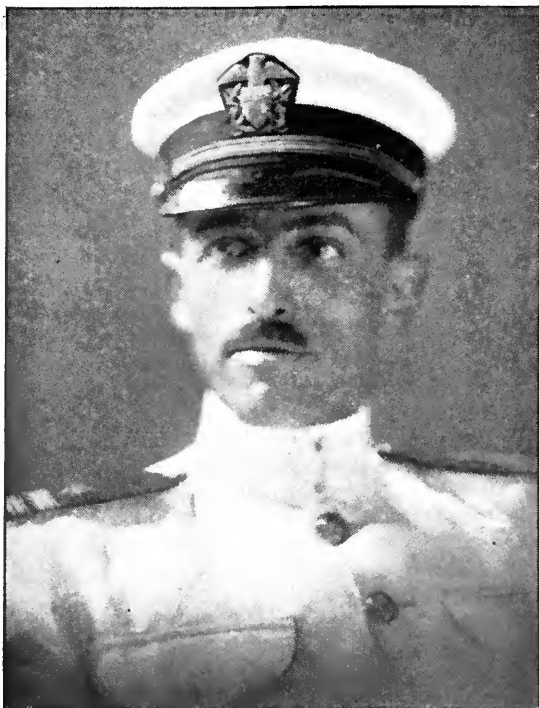

GEORGE LEWIS—ONE OF THE "OLD-TIMERS"

He has been actively interested in radio since 1908—possesses the first commercial operator's license issued by the U. S.—was in charge of field radio design for the Signal Corps in 1910—designed the first high-power military radio tractor and the first tuned-circuit transmitter, making air-craft transmission possible—was in charge of radio design division at the Navy Department during the War—organized and was first executive secretary of the National Radio Chamber of Commerce—and is at present with the Crosley Mfg. Co. as assistant to Mr. Crosley. He has traveled widely in this country, Europe, and the Orient, and is well known in radio circles here and abroad. As a recreation from work, Mr. Lewis writes poetry, plays golf, and enlarges his collection of artistic camera studies.

orate circuits which must be utilized to the fullest possible extent. The case is the same whether the operating man has charge of a broadcasting station, or is pounding the key in a ship's cabin, or has charge of a transoceanic station. In the broadcasting station one cannot afford to keep either the performers or the radio audience waiting. Marine radio conditions in congested districts are like the New York subways during the rush hour. There are always four or five ships lined up waiting to unload their messages. The land station gives its "Go ahead" signal to a ship, and the ship is expected to be there with its answer with a speed somewhat exceeding that of a faculty procession. In a transoceanic station the payroll and the investment are very high

and delays eat up the profits. The design and research people know occasional periods of leisure, but the operating man's job is often an uninterrupted rush; at least his ability to hold it is dependent on his ability to get things done fast at certain times. Thus if one has aspirations in the way of making a living in the radio field and one's natural tendency is to work slowly, however thoroughly and dependably, the best thing is to keep away from the operating end of the game.

Of course a man who gets dizzy on the deck of an auto bus *may* develop into a successful steeplejack—but the chances are against him.

#### RADIO ENGINEERS

**R**ADIO engineers fall into three classes: operating, designing, and research. Of course these categories overlap, and a competent engineer will not be lost in changing from one function to another. The operating engineer, as the term indicates, is concerned with actual handling of equipment. In this class, therefore, would fall the technical staffs of broadcasting stations, and the men who handle the machinery of high-power wireless telegraph circuits. The designing engineer, somewhat farther in the background, takes care of the layout of apparatus and its adaptation to specific uses. Farthest removed is the research worker, whose business it is to anticipate the needs of the future and to develop new and improved methods of transmission and reception.

What has been said above about the character qualifications of the operating man in general applies in every particular to the operating engineer. He must be quick in thought and execution and not easily rattled in emergencies. He must know how to cooperate with people who are not interested in and usually have little understanding of his problems, without letting the attendant difficulties get on his nerves. If he is a telegraph man, his contact will be with traffic officials and operators with little or moderate technical training and an overwhelming desire to get things running immediately, if not sooner, and to keep them running all the time, if not longer. The technical man may be nursing along a 200-kilowatt alternator out at some high-power station, and when the local lighting company drops the supply voltage a few notches he may have to ask the traffic people for time out to retune. In ten minutes the voltage comes back to



normal, and the job has to be done all over again. It takes only a few minutes, but to the traffic man, staggering under a load of urgent messages, those minutes are very precious. Or, at a receiving station, signals may be weak at times, and one has to explain why less high speed is being handled than last July.

Again, at a broadcasting station, the operator is the connecting link between the performer and the audience; neither must be kept waiting, and any interest they manifest in the technical features and difficulties is of necessity very casual. If a reactor breaks down in the plate circuit during a concert, and the set begins to go *glug-glug-glug* in the middle of *Caro Nome*, who will pity the poor broadcast operator or speak of him charitably on the commuters' express the next morning? Such an accident simply mustn't happen. And it rarely does. It is surprising, considering the newness of radio and the complexity of transmitting equipment, how rare and brief the interruptions are. But if this is so, it is not by any special dispensation of Providence, but by foresight, provision against weaknesses, ample safety margins, and unceasing observation and striving for improvement on the part of the men who design and run the sets.

The designing engineer converts ideas which have been found to work, into operable apparatus. The research engineer tries to dig up ideas which will work. They must work, of course, not only in the laboratory, but in the field. Hence the research worker requires a physical sense which will restrain and guide him in his search for new methods. Lacking this, his tendency will be to turn out plans for intricate and unstable apparatus which no amount of capable designing will save from the scrap-heap. At the same time he is usually a more imaginative individual than his colleagues in the other branches of the art, and his work is more closely allied to that of the artist or the pure scientist. He is frequently better versed in fundamental theory than the other classes of engineers; he must be, in fact, in order to be in a position to utilize the work of the pure scientists and mathematicians. It is



WHO WILL PITY THE POOR BROADCAST OPERATOR  
Or speak of him charitably on the commuters' express the next morning?

with the latter that novel ideas usually, though by no means always, originate. Thus we have an Oliver Heaviside investigating the properties of electrical lines and cables, and putting his conclusions into forbidding mathematical form, and a few decades later a Pupin digesting Heaviside's formulations, drawing practical conclusions, and ultimately producing the methods of inductance loading, which, with the development of the vacuum-tube amplifier, have made transcontinental telephony possible. The research engineer is thus on the second rung of the ladder which leads from ideas, more or less in the abstract, to concrete machinery operable by fallible human beings. A man well endowed with scientific curiosity, who wishes to work in an atmosphere of quiet and orderly pursuit of knowledge without regard to the vexatious details of practical application, is best off in academic research. With somewhat the same bent, but a little less zeal for reducing all ideas to a clearly expressed physical basis, and more tendency to turn out something which can be fitted into the complex machinery of industry, he may make a good industrial research man. Given still less preoccupation with ideas as such, and the type of mind which does not shrink from minutia—whether to use a 6-32 or an 8-32 machine screw, or how thick to make a panel, or how many turns of wire to use in a coil—always with an eye to the greatest durability and efficiency at the least expense, we have the material for a designing engineer. Of course, as in other fields, a capable man knows a lot about one thing and a good deal about everything

else. A first class designing engineer, for example, will be familiar with the outstanding ideas, at least, of men like Clerk Maxwell, Hertz, and Heaviside; he will have original ideas for improvements in the art and be at home in a laboratory; he will have the command of detail and knowledge of materials and manufacturing methods enabling him to draw up plans for efficient apparatus, and in a pinch he will be able to operate an actual station.

#### OTHER OPPORTUNITIES

**M**ANY other branches of technology might be mentioned in this outline of the varying functions of the radio engineer. The test shops, for example, have turned out some of the leading technicians in the field. In a test shop one learns, as in no other place, the method of operating, kinks, and limitations of

apparatus. Not only that, but one gains an assurance in handling apparatus which is hardly obtainable elsewhere. In a test shop an engineer gets his baptism of fire.

In one test shop where I worked it was the fashion to thumb one's nose at a short circuit arc immediately, if one retained the power of movement after the accident; no other reflex was considered *comme il faut*. Not that short circuits are welcome, but they occur in electrical practice, and in a test shop one learns not to be disconcerted when the fireworks start. And there are many tricks, such as the preliminary jerking in and out of the switch at the first test of a piece of apparatus, which form part of the equipment of a good electrician and save a great deal of money in the long run. There is no other place like a test room for learning these tricks.

#### RADIO DEGREES?

**P**EOPLE new to the field are sometimes influenced by the aggregations of letters which some of the experts and writers put after their names. Most of these mean about as much as the title of "Professor" prefixed to the name of instructors in boxing or the gentry who teach you to play the piccolo in four lessons. As yet no institution of good academic standing has established any such degree as "R. E.," for example, and, although a man putting these letters after his name may be a capable worker, they merely represent his own idea of himself and should be taken with the same reserve as advertisements in general. A certain discrimination should also be exercised in the matter of the weight given to membership in engineering societies. These organizations play an important rôle and everyone of consequence belongs to them, but it is not generally known that for an associate membership the only qualifications are interest—not necessarily competence—in the art, conventionally good business morals, and the ability to spend five or ten dollars a year for dues. For the higher grades—member or fellow,—some four and seven years of actual engineering experience are requisite, and to that extent membership in these grades has some bearing on the standing of the engineer in question. Holding of office in the societies, present or past, is of course an indication that the individual is respected by his colleagues and may be taken as safe evidence of high professional standing. Similarly, technical degrees from

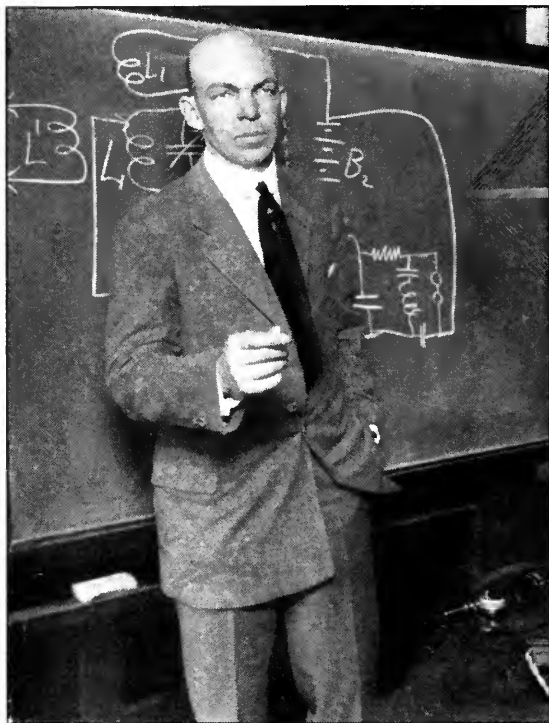

© and courtesy of Hearst's International Magazine

#### HE MADE RADIO HIS BUSINESS

Edwin H. Armstrong has been responsible, within the past ten years, for three of the most important radio developments. Before the War, he invented regeneration, which makes long-distance reception possible with a minimum of equipment. During the War, he devised a system of reception called the super-heterodyne, used at the time for intercepting enemy messages on very short wavelengths and now becoming popular for long-distance broadcast reception. Last year he disclosed his most recent invention—super-regeneration. Among the apparently unlimited possibilities of this form of reception is long-distance work with a single-tube loop set

universities of good standing, or study under acknowledged authorities, may reasonably be taken into account.

#### THE RADIO BUSINESS

THE business side of radio is hardly within the scope of this article; success is here a matter of general business acumen, plus special knowledge of the field and its particular patent and commercial difficulties. Broadcasting has of course changed the entire aspect of things in radio. It is only necessary to consider the case of one manufacturer whose experience dated back to the very earliest days of radio in the United States, and who maintained his business tolerably well in the spark-set years, and then, after almost two decades of moderate prosperity, failed when he tried to swing an ambitious program in manufacturing broadcast equipment. Apparently with the greater opportunities of the radio telephone boom he did not sense the instability of the new market, the necessity of meeting severe competition, and the adjustments required in manufacturing for a new class of users. So he went to the wall just as fast as any newcomer. In radio, as elsewhere, people who try to become millionaires in haste repent at leisure.

#### THE BROADCASTING GAME

BROADCASTING has opened up a considerable number of new positions. The personnel of a first-class station may include a program manager, who interviews prospective artists and makes arrangements for out-of-the-studio broadcasting, several announcers, and a technical staff, consisting of control operators, transmitter attendants, and outside or pick-up men. The control operator monitors the outgoing material and makes indicated adjustments, such as increasing or decreasing the amount of modulation, setting the accompaniment at the proper loudness relative to the singer, and so on. The transmitter operator watches the tube set, checking the wavelength and antenna current, and listening in at short intervals for distress signals at sea, which necessitate immediate shutting down of the transmitter. The outside men take care of acoustic exploration at theatres and halls from which special-event broadcasting is contemplated, the setting of the microphones, necessary tests, and supervision during the actual transmission. Of course in most stations there is not as much specialization as this,



© Underwood & Underwood

#### HE HAS HAD A FINGER IN MANY RADIO PIES

Elmer E. Bucher, born in Akron, Ohio, in 1885, and educated at the Academy in Oberlin, Ohio, joined the De Forest Wireless Telegraph Company as experimental engineer in 1903. Later, he was active as construction and installation engineer, organizer of radio schools, inventor, and radio editor and author. His "Practical Wireless Telegraphy" is the best-known of his many books on radio. He is at present managing the sale of amateur and broadcast equipment for the Radio Corporation of America

and one man may handle most of the routine of the studio. As soon as one gets into outside work, however, a good-sized staff becomes imperative.

An ear for music and sensitiveness to cacophonous elements are among the special qualifications of the broadcasting station operator. The more he knows about the engineering end—the special features of tube set operation, the technique of electrical voice reproduction, and so on—the better, but in addition to these fundamental factors he must be something of a musician and expert in practical acoustics. If he lacks these qualities, he will often be in the position of knowing less about the mechanics of his job than the performers in the studio, many of whom have had experience in the closely related field of phonograph recording. Social qualities are also of more importance in the broadcasting field than in other branches of the art, since the personnel of a station is in contact with outsiders of prominent position and good breeding. The broadcasting specialist, accordingly, has to try to make himself a combination concert hall manager and engineer. This question of general cultivation and social ease is likewise prominent in the selection of announcers.



### HE CAME, HE SAW, HE BECAME A RADIO MAN

At the age of sixteen, David Sarnoff persuaded the superintendent of the Marconi Company that he was the "Boy wanted." He soon became an operator, then manager of the Sea Gate station, then sailed to the Arctic as wireless operator on a sealing vessel. Returning, he enrolled as student in electrical engineering at the Pratt Institute night school, in Brooklyn. His next position was that of Inspector, then Chief Inspector for the Marconi Company. In September, 1922—at the age of 32—he was elected Vice-President and General Manager of the Radio Corporation. He is the man who, eleven years ago, received the message in New York, from the S.S. *Olympic*, 1400 miles at sea, giving first confirmation of the sinking of the *Titanic*



### FRANK M. SQUIRE, OF THE DE FOREST CO.

Starting in radio as an amateur, he entered the game professionally in the draughting end. He worked with the A. H. Grebe Company as draughtsman, and finally as Chief Engineer. Later, he organized the Radiocraft Company, of which he is now President, in addition to being Chief Engineer of the De Forest Company. His outstanding contribution to broadcast reception goes by the name of the De Forest D7-A Reflex Receiver

The writer has had occasion recently to give counsel on the matter of taking up radio as a profession to several young men of high school age, and an outline of his recommendations may be of interest to readers in somewhat the same position. The first desirable step is to get into practical touch with the field through amateur activities—reading the periodical literature, building sets, joining radio clubs and becoming junior members of the engineering societies. It is best to go to a college or technical school, specializing in electrical engineering—not that a B. S. or an E. E., as such, makes an engineer of a man, but it affords him a good foundation, enables him to make pleasant and valuable personal connections, and gives him, in later years, the satisfaction of feeling that he has not overlooked any good bets in preparation. This point is emphasized, it should be added, by associates of the writer for whom he has the highest respect, and who, lacking academic preparation, feel nevertheless that the time and capital is advantageously invested. Dur-

ing vacations, if it is at all practicable, the student should try to obtain temporary employment in commercial operating, as an apprentice or junior, or factory experience, less for the income obtainable in this way than for the value of coördinating practice and theory. Attention should be devoted to code practice and a commercial operator's license secured as soon as possible. Although radio's centre of mass may be shifting from telegraphy to telephony, the relations between the two will of necessity remain intimate; operators of broadcasting stations, for example, are required to have commercial telegraphers' licenses at the present time. On the other hand, it is clear from what has been said above that courses in the arts, such as a study of the history of music; and such experience as may be obtained in playing in a college orchestra, for example, will be quite valuable, even looking at the question from a narrow utilitarian viewpoint, without regard to humanizing and cultural influences.

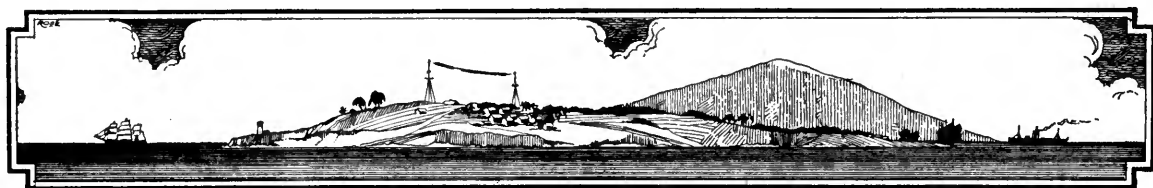

# Using the "Inverse Duplex" with Various Kinds of Tubes

By DAVID H. GRIMES

This article, written by the inventor of the Inverse Duplex circuit, discusses, from the standpoint of practical operation, the hook-up of which the theory was explained by Mr. Charles H. Durkee in the April number.

Since that first article appeared, we have been deluged with letters, some hundreds of them, asking every imaginable question about the theory, construction, and operation of the Inverse Duplex. The present article has been written by Mr. Grimes at our request, to answer many of the questions that have been asked by correspondents, and to let others know something of the possibilities of this circuit.

Briefly, the Inverse Duplex is a method of employing tubes for radio and audio-frequency work *simultaneously*, without overloading them—the heaviest audio-frequency currents flowing in the tube where the weakest radio-frequency current is flowing.—THE EDITOR.

**S**INCE the publication, in RADIO BROADCAST, of some of the details of the Inverse Duplex receiver<sup>1</sup> there must have been, conservatively speaking, at least two million questions asked concerning various parts of the circuit.

As a result of the much appreciated cor-

<sup>1</sup>"1,300 Miles on a One-Foot Loop," by Charles H. Durkee, April, 1923.

respondence, I have learned several things concerning the operation of the hook-up which would otherwise have taken me several years! And it is the purpose of this article to give the radio fan at large some of the benefits which I have received individually from him.

As with all new developments, there are many things which have to be known by the enthusiast before he can successfully dupli-

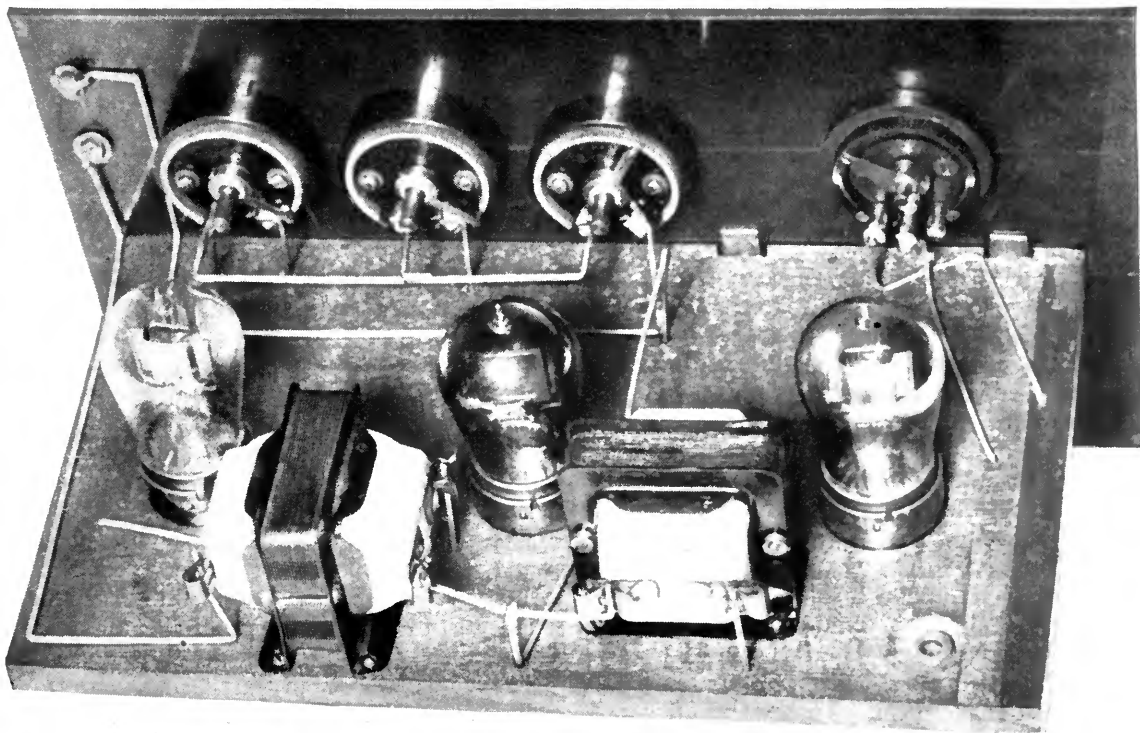

THE LAYOUT FOR THE AUDIO-FREQUENCY PART OF THE INVERSE DUPLEX

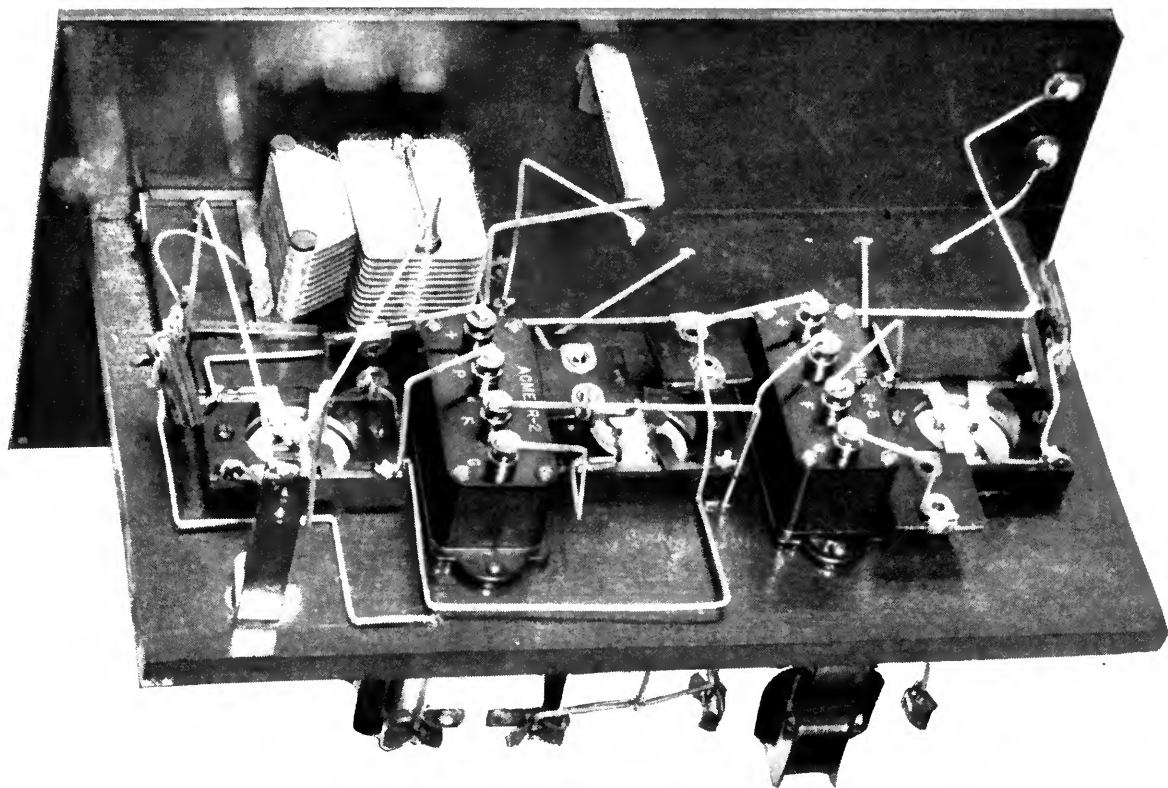

BOTTOM VIEW SHOWING RADIO-FREQUENCY ASSEMBLY FOR THE 3-TUBE CIRCUIT

cate the Inverse Duplex, even though he thoroughly understands the principle. Such supposedly simple details as equipment assembly, method of wiring, types of tubes, voltage of batteries, etc., immediately take on immense importance.

The circuit details disclosed in the April number of RADIO BROADCAST were necessarily applicable to only one type of apparatus, especially the tubes, as the purpose of that article was to outline theory, rather than practice. With the advantage of the theory fairly well appreciated, it may be of interest to you to learn what has been found *best in practice*, by myself and others.

Most of the troubles encountered in the operation of the Inverse Duplex arise from the radio frequency part of the circuit. If you have had little or no experience with radio frequency circuits, the following suggestions will prove helpful to you. All leads from the radio transformers to the grids, plates and bypassing condensers should be as short as it is possible to make them. These wires are carrying high frequency alternating currents and if run near other wires or apparatus they are

likely to "cross over" into them through the capacity between them, just as they do between the plates of a condenser. This will cause no end of trouble. The photograph showing the equipment layout indicates the closeness of the radio transformers and tubes.

Next, radio frequency amplification, unless properly designed, has a tendency to oscillate or howl and to the novice with little experience, it is almost impossible to stop it. This is mostly a problem of radio transformer construction, but even with a given transformer which tends to oscillate, there are several tricks which may be employed to stabilize it.

Radio transformers have to be pretty carefully built, and even then are best suited to certain types of vacuum tubes. Some transformers which are absolutely successful on, say, the Radiotron tubes, are very poor on any other type of tube. It is impossible, generally speaking, to use indiscriminately any type of vacuum tube with any type of radio transformer. Therefore, in purchasing your tubes and R. F. transformers, be certain that they are of a design suitable for operation with each other.

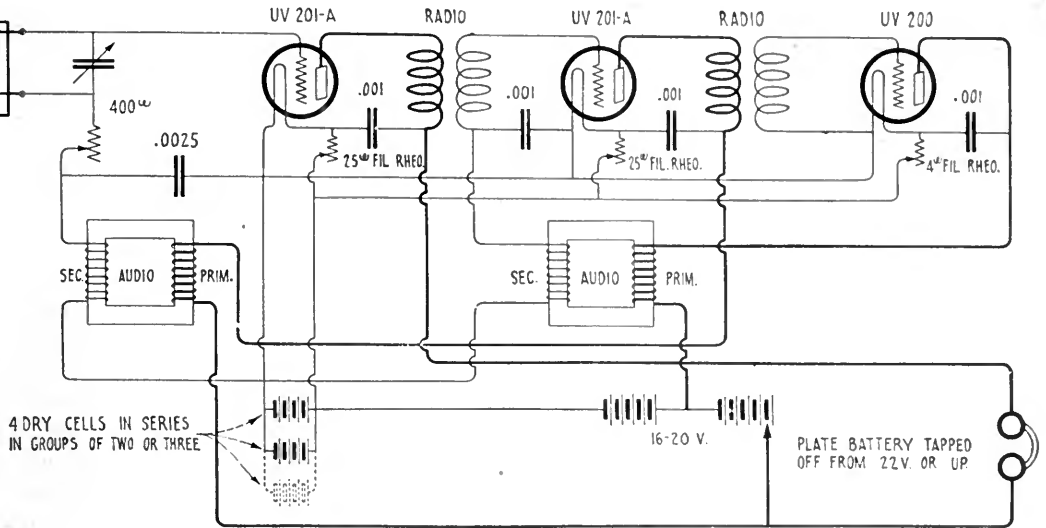

FIG. 1. HOW TO EMPLOY A UV-200 AND TWO 201-A'S  
 25-ohm rheostats are used for the 201-A's, and the common 4 to 6-ohm rheostat controls the UV-200. Dry cells in series-parallel are used to light the filaments

BEGIN AT THE BEGINNING

THE best possible way to proceed in wiring up an Inverse Duplex circuit is to connect up merely the two stages of radio and a detector to start with. If no results are obtained on this, it is useless to expect anything by adding the two stages of audio. The audio stages function to make louder the results already obtained by the detector tube. Hence it is absolutely necessary to secure results there before proceeding further.

One of the features of the Inverse Duplex circuit is the easy and ready way in which trouble may be located. The hook-up can be cut into three separate and distinct circuits—the radio, detector, and audio connections. Any one of these three may not be operating properly due to troubles common to radio circuits, detector circuits, or audio circuits.

For instance, on loop reception, it is somewhat difficult to make a so-called "hard" tube, such as the UV-201, act properly as a detector on only two stages of radio. On the

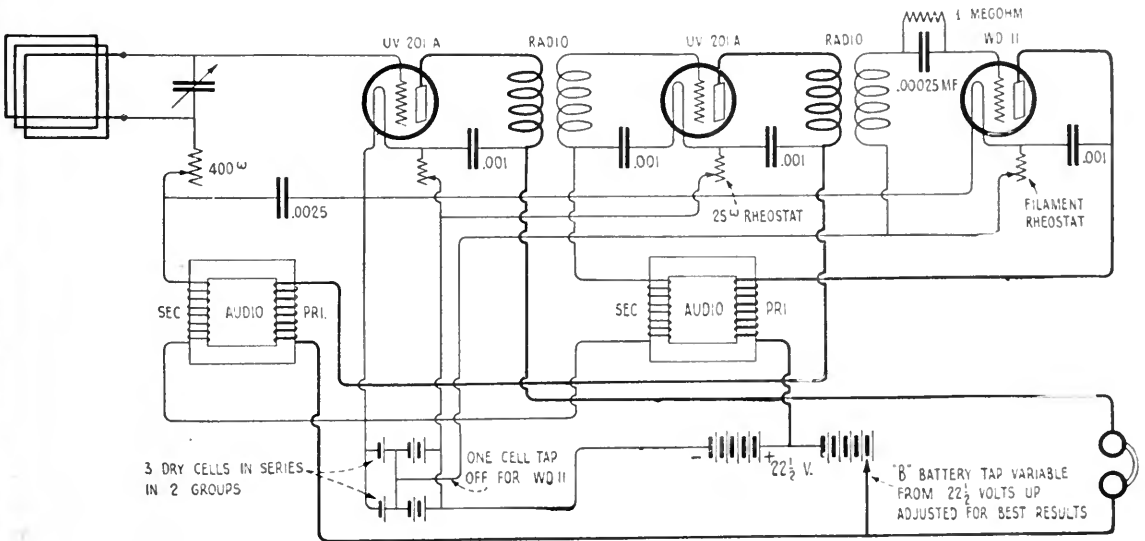

FIG. 2. THE SAME CIRCUIT ADAPTED FOR USE WITH A WD-11 OR WD-12  
 Note the 1½-volt tap-off for detector-tube filament

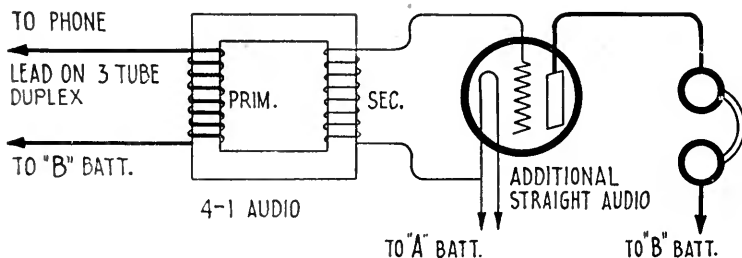

FIG. 3.  
SHOWING HOW TO ADD A STAGE  
OF STRAIGHT AUDIO TO THE IN-  
VERSE DUPLEX

other hand, a "soft" tube such as the UV-200 will do this easily. There are detectors and detectors, varying over all known ranges of sensitivity. A great deal will depend, naturally, on the sensitivity of your detector for best results. The April article recommended a UV-200 tube as a detector. This tube does not require a grid condenser or leak and the grid wire should lead back to the negative side of the filament. A UV-201 or 201-A tube is not recommended here for a detector.

#### USING DRY CELL TUBES

THIS brings up the dry-cell situation as applying to my circuit. The same thing holds true in this case. When satisfactory radio amplification is obtained and successful detection is secured, the rest is easy. The new UV-201-A tubes which will operate on low enough currents to permit their use with dry cells, cause considerable difficulty in radio circuits unless special precautions are taken. I have found that the easiest way to secure stability with these tubes on radio frequency is to drop the plate voltage to 45 volts and sometimes even lower. Dropping the filament voltage below 5 volts often helps.

For a detector tube on dry cell operation, the UV-200 can hardly be recommended because of the high filament current required. It is possible to use it but several banks of dry cells must be connected in parallel to hold up for any length of time. The expense of such operation becomes greater than the maintenance of storage batteries and is not advisable. The UV-201-A tubes have, in my experience, not responded as detectors to weak enough signals to permit their use with only two stages of radio on a loop. The WD-11 is apparently much better but requires a different line-up in the filament battery circuits. It operates on only about 1 volt while the UV-201-A tubes function on from 4 to 5 volts.

Many questions have arisen regarding the omission of the filament rheostats on the

amplifying tubes in earlier drawings. These were purposely left out because the UV-201 tubes would take the battery voltage (about  $5\frac{1}{2}$  volts after the filament current had gone through the battery leads) directly, with only a small decrease in their life. It was thought that omitting these rheostats would simplify the adjustment of the set to a sufficient degree to compensate for the somewhat shorter life of the tubes. The confusion, however, has been so great that I am now suggesting that the amplifying tubes have rheostats inserted as shown in the accompanying diagrams (Figs. 1, 2, and 5).

Having assumed, now, that the radio frequency part of your circuit has been adjusted to function satisfactorily, we are ready to consider the specific difficulties encountered in duplexing the audio on the radio tubes. Most fans have little or no trouble with audio circuits, or if they have, they have learned how to overcome them, by reversing the primary windings, etc. The reversing of leads on the primaries of the radio transformers, by the way, is a good thing to try when troubled with instability in the radio frequency circuit.

You will no doubt recall what was said in the April issue about overloading the tubes in certain types of "reflex" circuits. It was also brought out that the Inverse Duplex greatly helped in overcoming this trouble by balancing the load. Even then, if the incoming energy is excessive, as is the case on aerial reception for local work, the carrying limit of the tubes is reached and poor quality results. In this case, the 400-ohm resistance would not be sufficient to cut the energy down to a reasonable amount. WD-11 tubes are not very satisfactory as amplifiers in this circuit as they are limited in energy and are easily overloaded. This circuit is essentially a super-sensitive layout and will not stand tremendous currents. If louder reception is desired on local or long distance stations than that given by two stages of audio, it is suggested that an



additional tube of straight audio be added between the set and the reproducer. The sole purpose of this tube will be audio amplification and can be used to the limit of its ability for that purpose. If greater range is desired, a straight radio stage may be connected between the loop and the first duplex tube, but, of course, this has a tendency to overload the duplex tubes on local reception. Running three duplex tubes beside the detector is not to be recommended to the uninitiated, although it has worked out perfectly in hundreds of cases during the past year. Until the amateur has fully familiarized himself with the duplex peculiarities on two amplifier tubes, he should not tackle the three-amplifier layout.

#### ANY LOOP WILL DO

A ONE-FOOT loop was referred to in the previous article and this has led to much confusion. Many readers inferred that the circuit would operate with nothing else. Any kind of a loop will work on the circuit provided the number of turns are such as to tune properly with the variable condenser for the wave lengths desired. The smaller the loop, the less energy it will pick up and the less will be the range for a given sensitivity of circuit. Many other types of sets have operated over considerable distances on loops ranging all the way up to 5 feet on a side or even larger. The one-foot loop was emphasized merely to illustrate the extreme sensitivity of the circuit. On powerful stations up to 175 miles away, I

have obtained good reception on a 4-inch coil—the secondary of a variocoupler. For best all-round results, a 16- to 20-inch loop with 8 to 12 turns of wire, spaced  $\frac{1}{4}$  inch apart is suggested. On a three-foot loop, a listener in New York using the Inverse Duplex circuit with two tubes and a crystal detector, has picked up stations as far west as Kansas, *at noon*. This size loop has a tendency to overload the circuit on night reception. Overloading is easily ascertained by poor quality or the first or second amplifying tube acting as a detector instead of the regular detector tube.

#### TWO WAYS OF OVERCOMING "SILENCE"

AFTER all the above suggestions have been followed, there will be cases, no doubt, where the fan will still have trouble. There are so many variables which can cause trouble. I would recommend trying two additional changes which ordinarily are not desirable. The first is to run the grids of both amplifying tubes back to potentiometers instead of to the negative filament, and the second is to cut down or perhaps eliminate entirely the bypassing condensers on the middle tube. This first gives broad tuning and also reduces the audio, while the second materially reduces the range.

The audio transformers should be of the  $3\frac{1}{2}$  or 4 to 1 ratio preferably. Under certain conditions, especially when using a crystal for a detector, the first audio transformer after the detector can be of the high, or 10 to 1, ratio.

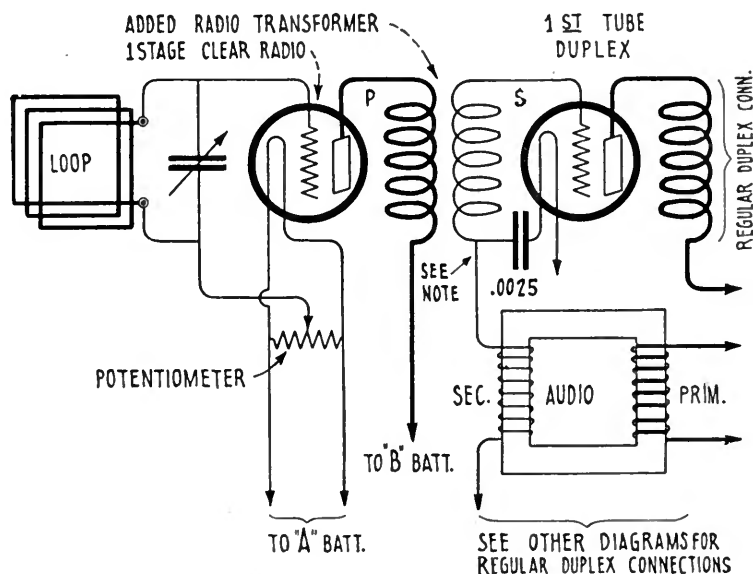

FIG. 4.

HOW TO ADD ONE STAGE OF STRAIGHT "RADIO" TO THE INVERSE DUPLEX

Where UV-201-A tubes are used, 25-ohm rheostats should be connected in series with the filaments. The same thing applies to the arrangement shown in Fig. 3

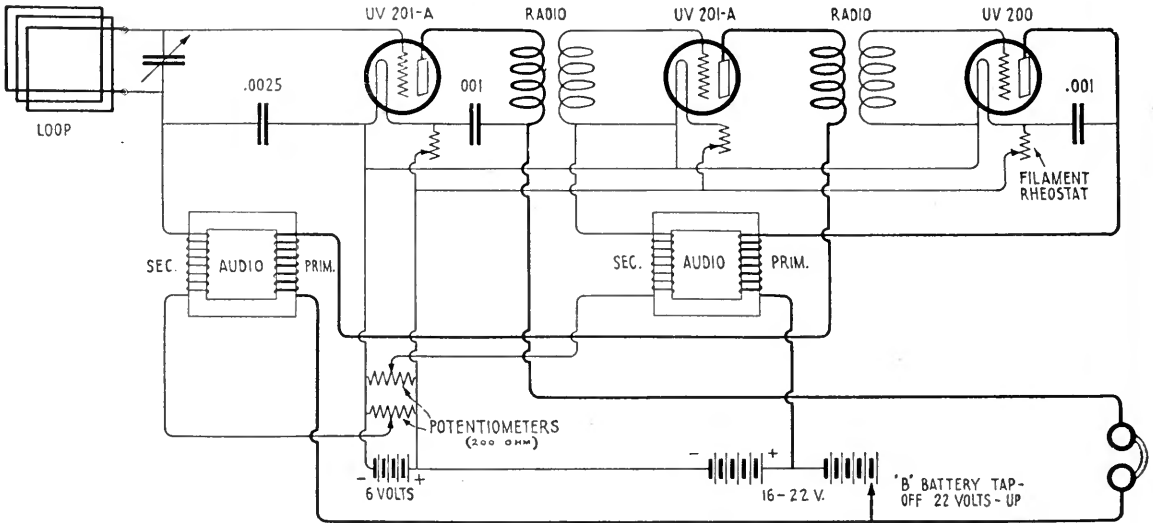

FIG. 5. THE STABILITY OF THE CIRCUIT IS IMPROVED BY TWO 200-OHM POTENTIOMETERS

Note that in this case there is no by-pass condenser on the second tube

It is assumed that the ordinary troubles possible in radio hook-ups, such as open transformers, poor tubes, broken down condensers and run down B batteries, have been located and eliminated. It is naturally beyond the scope of this article to cover all these points, but nevertheless they must first be checked before any success can be obtained. Fully nine out of ten troubles which I have been personally called to remedy were due to such things as mentioned above.

If I have in any small degree helped the radio fan along, I shall feel amply repaid, and to those who have not achieved all the results they had a right to expect, I can only suggest that they accept the advice on the back of one of the earlier automobile handbooks: after all the cures for possible automobile troubles have been given throughout a vast number of pages, the final statement is made, "Don't forget that this machine once worked, and with proper care will work again."

## Radio is Expensive for the Married Man

By ROBERT OLIVER

**R**ADIO, relatively speaking, is not very expensive when indulged in by a single man, but when a married man succumbs, it is different. Not, as you may have hastily concluded, because the places where radio apparatus is exposed for sale make a practice of jumping a married man harder than they do the bachelor, but because of one item in the total cost which is submerged.

If you are a married man, and, like many another, goaded to a point where you feel like an outsider amid the jargon of radio fans, you

may decide to investigate and perhaps invest. But listen. There is one item that belongs on the list of what to buy that you never can dodge.

This item belongs in the class of things that you can not say with words. Florists advise saying it with flowers.

If one could get by with flowers it wouldn't be bad. But flowers don't seem to suffice. One man I know had to get his wife a new car and teach her to drive it. Thus, when he came home at night with his arms full of parts he could pretty safely bank on his wife's being out with the car.

Take my friend Jennings. Before the radio mania seized him, he was as keen a conservator of the old savings account as one could wish to meet. Now Jennings has a one-man radio factory going full blast in his basement, but the price he pays for it is terrible. His wife has an ermine cape and has already priced certain articles of jewelry involving platinum.

Possibly the prospective married radio enthusiast who has an idea that a couple of hours will be sufficient to put together a set may pause when he learns that radio takes time. It takes time to shop around for apparatus. It takes time to read radio magazines. One must read the radio advertisements. One must study all the new hook-ups and figure out the weekly, one might say daily, batch of super circuits.

As for any one particular hook-up, its days are as grass: as a flower of the field, so it flourisheth; for the wind-of-something-new passeth over it, and it is gone; and the place thereof shall know it no more.

Take the radio fan's Sunday. Almost any Sunday will do. His routine is something like this.

7:00 A. M. The fan wakes up and wonders if a C battery wouldn't help his second step. He resolves to try it and gets so interested in the idea that he can't go back to sleep.

7:15. Gets up and turns off the current on his battery rectifier.

7:25. Fixes furnace and makes a side trip to work-bench. Inspects new set he is working on. Finds a couple of loose connections.

7:30. Lights laundry stove to heat soldering iron. While soldering iron is heating, decides to substitute bus bar for bell wire in connections from filament.

8:00. Remembers that rheostat for first step makes poor contact, decides it is good time to take it out and put in new one bought yesterday.

9:00. Wife calls breakfast. Soldering iron poised in midair. "Can't stop just now dearie, be there in a minute." Finishes soldering, puts tools away and discovers two loose taps on inductance. Better fix it while iron is hot. Iron is cold, so lights gas and waits for iron to heat.

9:30. Taps all fixed, tears himself away, shaves and dresses. Comes down to breakfast. Wife and breakfast cool.

10:00. Goes down to fix furnace again. Makes another side trip to work-bench.

Starts tracing out grid and plate circuits. Finds grid leak connections very loose. Better solder them. Lights gas and waits for soldering iron to heat.

11:00. While iron is heating decides to put some spaghetti on plus A lead to prevent getting it crossed with 90-volt B which is bad for tubes.

11:30. Too late to go to church. Wife gone to church. "Oh well, 'sall right. Get a little time to myself now." Starts laying out some radio frequency.

12:30. Still laying out radio frequency. Decides to get another radio freak transformer to-morrow. Saw one advertised in magazine.

1:00. Mess call. "Just a moment dear, can't come just now. Be there in a minute."

1:30. Responds to mess call. Wife and mess decidedly cold.

2:00. Mess over. Not a very chatty meal.

2:15. Decides it might be a good plan to "say it with an automobile ride." Skies brighten a bit at suggestion. Goes down to



"CAN'T STOP JUST NOW, DEARIE, BE THERE IN A MINUTE"



"I'VE BEEN THINKING,  
MY DEAR  
That you need a rest. How  
would a trip to California strike  
you?"

fix furnace. Makes side trip to bench to see if everything is all right. Everything not all right. Left gas burning and soldering iron is red hot.

2:20. Decides to solder a couple of connections while iron is hot.

2:45. Still soldering. Can't make 'em stick. Too big a hurry. Gets sore and hot.

3:00. Still soldering. Hears noise upstairs. "All right dear, be there in a moment."

4:00. Goes up. Finds wife gone out. Noise was door slamming. "Oh, all right. It'll gimme a little time to myself. Gosh, women are unreasonable."

4:10. Goes down to work-bench, now that he has a little time to himself, and works on radio-frequency hook-up. Decides to drill new panel bought yesterday.

5:00. Panel all drilled. Might as well mount condenser and rheostats now that he has a little time to himself.

6:30. "Gosh how time flies." Wonder if the wife has returned. Wife still out. "S'all right, now I've got a little time to myself."

8:00. Wife returns. Brrr!

8:15. Hooks up set and listens in. Gets sermon entitled "One Day of Rest in Seven."

8:16. Decides to try to get distant

stations. Local stations too strong.

8:30. Quits and goes down to fix furnace. Wishes radio-frequency hook-up was finished. Better go and look over radio-frequency hook-up. Makes side trip to work-bench.

10:00. Still working on radio frequency. Glances hurriedly at watch. Wow—10 o'clock already!

11:00. Prepares "temporary" hook-up of radio frequency. Tries it. Doesn't work. Takes it back to basement. Decides to put in condensers on transformers.

12:00. All set again and ready to try. Local stations silent. Doesn't work. Goes over hook-up plans again. Remembers article in magazine on radio frequency.

12:30. Funny where that magazine went. Goes back

and tries radio-frequency hook-up again. It works but not very well.

1:00. Decides to quit and call it a day.

Gentle reader, perhaps you begin to gather the importance of doing something to thaw out the frigidity resulting from such a schedule. The only way is to search out some of the wife's repressed desires. See if she hasn't a complex centering around a trip to California. Every woman has such a complex, something that comes to the surface every now and then, under stress.

Decide upon the particular complex that makes its presence known most frequently. Then, with casualness, not to betray the hidden motive, say something like this: "I've been thinking, my dear, that you really need a rest. I can't get away myself, but how would a trip to California strike you?"

Try to find the California trip complex if possible. It is really much better than a fur or diamond complex. I'll tell you why. Although furs and diamonds are more enduring and in times of great stress may be hypothecated, perhaps, still there are advantages about a California trip for the wife which should not be overlooked—by the fan who wants a little time to himself.

# Putting Your Patent Across

How to Choose Your Lawyer. A Word About Foreign Patents. Some Popular Illusions Mercifully Destroyed

By ROGER SHERMAN HOAR, A. B., M. A., LL. B.

Former Assistant Attorney General of Massachusetts

**T**O MOST inventors, the patent law seems a maze of complications. It seems complicated merely because everything unknown is mysterious.

But as soon as its principles are separated from technical terms and from the usual hocus-pocus with which some lawyers are fond of mystifying their clients, it becomes a lucid subject, easily understood.

On the other hand, everything about which you have a smattering of knowledge seems easier than it really is.

Now, it is possible for any intelligent inventor to handle his own case from start to finish, by following the book of rules issued by the Patent Office. In some instances it may be desirable for you to handle your own case, as for instance when you are filing your application merely for the purpose of saving the expense of a "search," or for the purpose of ascertaining what some competitor may have up his sleeve.

But, in general, "a man who is his own lawyer has a fool for a client." Did you ever notice, in reading the newspapers, that whenever a lawyer gets into trouble, he does not try to handle his own case, but rather hires the most able and expensive brother lawyer whom he can find. If lawyers, who know all the shortcomings of their own profession from the inside, and who are much more able to handle their own cases than any layman could possibly be, nevertheless consider it advisable to employ an attorney, how much more advisable is it for a layman to do likewise! To show that I practice what I preach, I will state that at present I have three applications of my own pending at Washington, and that each of them is in the hands of an attorney other than myself.

Since April, when this series of articles started in RADIO BROADCAST, I have been deluged by letters from readers, and a large proportion of these have been from inventors inquiring as to how to choose a patent attorney.

A great many inventors are perplexed by the apparent *impasse* created by the fact that the only way to find a lawyer is by his advertisement, and that reputable lawyers do not advertise. Although it is true that the ethics of the profession do not permit lawyers in general to advertise, yet, in the first place, it is not unethical to use an advertisement merely stating one's name, one's address, one's phone number, and the fact that one is a lawyer, specializing in certain sorts of cases; and, in the second place, the rule against advertising has been considerably relaxed in the case of patent lawyers, for they are not in as good a position to get business by other means as are general practitioners.

So don't worry about whether your lawyer advertises or not, for plenty of reputable patent lawyers do advertise. But be sure and give heed to what he claims in his advertisements. And especially avoid lawyers who guarantee results, for the mere fact that he can get you a patent on your invention means practically nothing. You may have a perfectly wonderful invention, and yet secure an absolutely valueless patent based on it, especially if you employ a guaranteeing attorney.

There's nothing wonderful in being able to guarantee results! It is the simplest thing in the world to secure a patent! I, here and now, will guarantee to get any one a valid patent on anything under the sun, new or old, provided only that it has some detail, however slight, to distinguish it from the prior art; but this is not particularly clever of me, for any other attorney could do the same. We would not, however, promise that the patent would be worth the paper it was printed on.

Closely akin to the patent attorneys who guarantee results are those who *impliedly* guarantee results by making their fee contingent upon success. What do they mean, "success"? Contingent fees are proper, and even desirable, in certain fields of the law, notably personal injury suits and will-contests, for

in such cases the client can ill afford to pay a cent if he loses, but can well afford to pay a quarter, or a third, or even a half, of his total recovery, if he wins. Even in such cases, there is a temptation for the lawyer to make a quick settlement for the certainty of a small fee, rather than to do the extra work necessary to secure a larger recovery. But, be that as it may, there is *no* excuse for a contingent fee in any situation where it is impossible to measure accurately the value of the results.

The third class of lawyers to avoid are those who charge a uniform fee, regardless of the amount of work involved. It stands to reason that they will give just as much attention, and no more, to the case, than is necessary to secure some sort of a patent.

It is hard to say which is the worst: guaranteed results, contingent fees, or uniform charges, for they all are akin.

If you are interested merely in getting a patent on your invention, then by all means go to such an attorney. But if you want a patent carefully drawn, so as to secure you the maximum protection against infringement, consistent with the state of the prior art, within the allowable range of equivalents of the elements of your invention, then you should avoid a shyster lawyer as you would avoid a quack doctor. Go to the best firm you can afford, and be prepared to pay them well, on a time basis, regardless of results.

It is not necessary that your lawyer be an expert in your particular field, for lawyers are notably adaptable. At the Coast Artillery School during the War, some statistics were compiled to show the relation between previous education and standing in War studies, the object being to induce highly trained technical men to choose the Artillery branch. The figures came out just as expected, with one startling exception; or rather, addition. The lowest grades were those of grammar-schooling or less. Then came the high school graduates. Then the college graduates. Then the holders of advanced degrees: M.A. and Ph.D. in mathematics, Civil Engineer, Mechanical Engineer, Electrical Engineer, etc. But, far in advance of all, in a group sufficiently large to show that it did not exist by mere chance, stood the holders of the LL.B. So, in order not to spoil the statistics, the Army authorities lumped the lawyers in with the engineers, under the head of "and other advanced degrees."

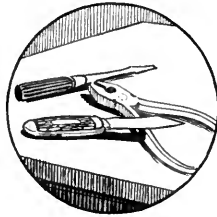

This episode shows us that the law-trained man is, by nature, so adaptable that it is easier for the average lawyer, with no technical experience at all, to master a branch of engineering, than it is for an engineer to switch from one branch of engineering to another. So don't worry about your lawyer's ignorance of your particular line.

It is much more important for a lawyer to understand judicial psychology (i. e., the mental processes of his courts), than it is for him to be versed in the law; so, all other things being equal, choose a former Patent Office examiner to handle your applications. But, if possible, choose one who has been graduated from a law school of standing, as otherwise you are not getting a really law-trained man.

For searches, choose an expert in this line of work. Several former Commissioners and Chief Examiners have made conspicuous reputations

in this field.

For foreign patents, there are firms who do nothing else, having their representatives in every country in the world. Most local patent attorneys are totally unfitted for this work; but you should have your American lawyer cooperate with your firm of international lawyers.

For drawing assignments and similar papers, a general practitioner is preferable to a patent lawyer, as such papers are governed by the general, rather than by the patent, law.

For court-work, choose a good trial lawyer, who understands the psychology of the particular judge before whom the case is to be tried, but have your patent attorney sit in with him. Some of the best patent-trial lawyers in the country have never handled a single patent application, and some of the most skillful claim-drafters have never appeared in court.

When a person wishes to buy or sell a patent, the thought naturally occurs to him to secure an abstract of title from the Patent Office, just as one does from the Registry of Deeds when dealing with real estate. But there is a great difference. In the case of real estate, a bona fide purchaser cannot be affected by a deed which has not been recorded; but in the case of patents, unrecorded papers frequently spoil the entire title.

Interests in patents can be vested in assignments, in guarantees of exclusive territorial rights, in mortgagees, and in licensees.

An assignment conveys the whole interest of the patentee, or an undivided part thereof, extending throughout the whole United States.

A grant conveys exclusive rights under the patent throughout some specified part of the country.

The meaning of "mortgage" is well known.

A licensee is one who takes an interest less than or different from any of the aforementioned. A license may be oral, written or printed, and if written or printed must be duly signed. In the absence of words to the contrary, a license is personal to the licensee, and cannot be transferred.

Assignments, grants, mortgages, and possibly exclusive licenses, must be written or printed, must identify the patent by date and number (or, if the invention be unpatented, must give the name of the inventor, the filing date and the serial number, if any), must be duly signed and acknowledged before a notary or similar official, and must be recorded in the

Patent Office within three months of execution, or at least prior to the execution of any subsequent purchase or mortgage, in order to be valid as against such subsequent purchase or mortgage. It is said that the subsequent purchaser or mortgagee has "constructive notice" of the recorded conveyance. Actual notice by the purchaser or mortgagee, prior to his acquiring title, is equally effective to invalidate the subsequent purchase or mortgage.

And now, I suppose, you would like to know something about foreign patents. Obviously the subject can merely be sketched in the brief space that remains to me; so let us call this merely an *introduction* to foreign patents.

If you decide to patent abroad, you will wish "to get in under the Convention"; i. e., to file abroad within one year of the filing date

of your American application. The Convention is a treaty between most of the civilized countries of the globe, whereby an inventor will not be penalized because of the publication or use of his invention within a period of 12 months from the filing of his first patent application. Under the Convention, an applicant is safeguarded for one year from the date of

filing his first patent application; and, so long as he files foreign applications (in the countries party to the Convention) within 12 months from the date of filing his first case, his foreign applications will be immune from attack on the ground of any publication or use of the invention that may have taken place in the interim.

In the United States the date of conception of the invention is what counts, but in practically all foreign countries the applicant must stand or fall by his filing date. Thus in most foreign countries, a published description or public use of an invention prior to the filing of an applica-

tion will forever prevent a patent, unless the inventor gets in under the Convention. In some of these countries the publication must be local, but in others a foreign publication will bar.

In case you do not wish patent protection abroad, but merely wish the field left clear for yourself, you can prevent others from obtaining a valid patent on your invention, by publishing a description thereof in the countries in question. This description should be full enough to enable any skilled person to duplicate the device.

In considering the foreign field, bear in mind that if no publication or use has taken place, a valid patent can be obtained; but that otherwise a valid patent is possible only under the Convention. An invalid patent, however, is better than none.

According to Mr. Hoar, most people are possessed of a number of erroneous ideas regarding patent law and procedure. In this article, he sets you right, with a jolt, perhaps, but with no less shrewdness and accuracy on that account.

Until you have read this article, you may be under the impression:

That sale is the only sort of infringement. This is not the case.

That an inventor can continue to manufacture his own invention after selling his patent. Not so.

That joint owners must split fifty-fifty. No such thing.

That it is wise to hire a patent lawyer on a contingent fee basis.

Quite the contrary.

It is very agreeable to have some of the prevailing "mysteries" of the patent game clearly exposed and explained. We commend this article, and the three in the series which precede it (April-June, 1923), to all our readers who have even the slightest glimmer in the back of their minds of an idea which might some day be developed into an invention worth patenting.—THE EDITOR.

The cost of patent proceedings varies greatly in foreign countries, and is complicated by the cost of translations, patent taxes and "workings," none of which exist in America. Of course, different firms charge different amounts, but the following represents a fair average.

Translation, one dollar per hundred words in most countries, but running as high as three-fifty in some. Drawings, five or ten dollars a sheet. Fees and legal services, from forty to two hundred dollars, depending on the country.

In most countries, patents are subject to an annual tax, usually starting either immediately on filing, or immediately on issuance, or a few years thereafter, and gradually increasing during the life of the patent. Non-payment forfeits the patent. In some countries, there is merely an extension fee required, once in the case of 14-year patents, or twice in the case of 20-year patents. A few, notably Canada and some Latin American countries, have no tax.

In nearly all foreign countries, no search, or at most a mere perfunctory examination, is made by the patent office. The patent is advertised, and if no objection is filed within a certain period of time, it issues as a matter of course. But Canada, Germany, and Great Britain proceed by office-action and amendment, very much as does the United States. Some countries, in the case of applications under the Convention, require the filing of copies of all American actions and amendments.

In nearly all foreign countries, the patentee must, within a certain number of years, commence the local manufacture of his invention on a sufficient scale to satisfy the local demand; as otherwise the patent will become void. This is called "working." But in some of these countries, a "nominal working" will do. This consists in advertising for someone to build your invention, and then in the rare eventuality of someone taking you up, making your terms too hard for him. Or in some countries, it is sufficient to mark your patent "license of right," which means that you will license any one who applies. This may sound dangerous; but in Canada, out of all the hundreds of patents so marked, only one such license has ever been required.

Some countries, notably Canada, prohibit the importation of the patented article by the

patentee, under penalty of forfeiture of his patent. But the law is usually satisfied by Canadian manufacture of the parts vital to the patented feature, American manufacture of the rest, and assembly in Canada. Similar acts will also satisfy the working requirements of most countries.

In many British colonies, a British patent can be registered at any time during its life, and thereby becomes effective locally for the rest of its duration. A similar rule exists in certain Danish and United States colonies. But in a very few British colonies, local use or publication will bar filing. And in another very few, use abroad by others than the inventor will bar filing.

The life of a foreign patent varies from five years in some countries to twenty-one years in others, the prevailing period being fourteen or fifteen years.

I strongly advise any inventor against foreign patents, unless he is backed by a corporation sufficiently affluent, pugnacious, and liberal to defend his rights, or unless the invention is epoch-making (which, unfortunately, most inventors consider all their "brain-children" to be). For it is a comparatively simple matter for a determined local competitor to upset the patent of an absentee.

A large part of these articles has consisted in the puncturing of popular fallacies. Therefore what more appropriate way is there for concluding the series than to give a list of deadly parallels setting forth each of the prevailing misconceptions; and, in contrast to each, the truth. This list will follow as closely as possible the order of the preceding text, to which the reader can refer for more detailed enlightenment.\*

The deadly parallels are:

1. That the ownership of a valid patent is a guaranty of your right to manufacture the patented article. On the contrary, you are more than likely to be barred by at least one earlier patent.

2. That sale is the only sort of infringement. On the contrary, manufacture is infringement, and use, even by an innocent purchaser of a machine, may also infringe.

3. That no damages can be collected for an

\*The three preceding articles in this series of four, are: "What Good is a Patent?" in the April number; "What Can Be Patented?" in the May number; and "Protecting Your Invention", last month.

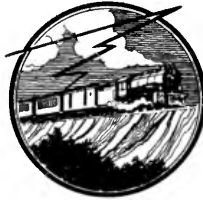



infringement which doesn't make money. On the contrary, the patentee can collect three times what *he* would have made, if you had not taken away his trade.

4. That use purely for amusement is not infringement. On the contrary, it is infringement, if the device is an amusement device.

5. That, if you invent something first, no subsequent inventor can prevent you from using your own invention. On the contrary, he may quite likely obtain a patent which will be held valid, in spite of proof of your earlier conception, and thus may enjoin you from using your own device.

6. That joint owners of a patent cannot act alone. On the contrary, any one of them can issue a valid license under their patent.

7. That joint owners must split fifty-fifty. On the contrary, neither of two co-owners is responsible to the other, in the absence of an express agreement.

8. That the invention of a technical employee, invented in the course of his employment, belongs to his employer. On the contrary, there are many situations in which it does not, even though the invention is applicable to the employer's business.

9. That it is a harmless courtesy to include your helper or your boss as a joint inventor. On the contrary, this may invalidate your patent.

10. That an assignment of all future inventions is void, unless it contains a time limit. On the contrary, a limit as to subject matter is equally effective.

11. That an inventor can continue to manufacture his own invention, even after selling his patent. On the contrary, a patent, once sold, is *gone* forever.

12. That there is some magic in having the inventor's first drawing bear the signatures of *two* witnesses and be attested by a notary. On the contrary, the real requirement is the assurance that at least one outsider has understood the invention on the date in question, and will so testify convincingly in court.

13. That when some prior patent is cited against your application, you must execute some sort of paper admitting its validity. On the contrary, you can avoid the citation by showing either that your invention does not come under it, or that your invention, although subsidiary to the other, yet constitutes an improvement upon it.

14. That the mention of some prior patent in a printed specification shows that some such paper, as mentioned above, has been filed. On the contrary, there is no such thing. This mention is usually either for the purpose of shortening your description by referring to some well-known prior device, or for the purpose of obtaining the benefit of the earlier filing date of some other application of your own.

15. That patent office tactics are no concern of the inventor. On the contrary, many a patent proceeding has been spoiled through the failure of the inventor to keep intelligently in touch with the different moves which his attorney was making.

16. That there is something wonderful in a lawyer's being able to guarantee the securing of a patent. On the contrary, I myself will guarantee to get any one a patent on almost anything, old or new; but I will not guarantee that this patent will be worth a nickel.

17. That it is wise to hire a patent lawyer on a contingent-fee basis. On the contrary, a patent application is unlike a damage suit, for in the case of a patent it is impossible to measure the value of the results. A contingent-fee patent case is likely to be carelessly handled.

18. That a clear abstract of title means a clear title. On the contrary, there may be outstanding a valid license, which has not been recorded in the Patent Office.

19. That, at least, the ownership of a valid patent clears you of all prior patents which were not cited against your application. On the contrary, your patent may infringe some patent of which you have never heard, and yet may be clear of many which were cited against it.

20. That the patent examiner exhausts the prior art. On the contrary, patent examiners are overworked and underpaid; and often issue a patent which is absolutely void because of some overlooked prior patent which is directly in point.

In general, remember that nearly every bit of current belief about patent law is decidedly *not* so. The more that anyone says, "Oh, everybody knows that!", the wiser it will be for you to run to some authoritative book and *look it up!*



# The Set the Boy and His Dad Built

By ARTHUR N. KING

(Dad)

SAY, Dad, if you will help me get a radio set, I'll stop wanting a bicycle." Dad said, "All right," and so the work was begun.

The boy had made several attempts at winding coils and finally had made a very good loose coupler from material obtained at a five-and-ten-cent store. A crystal detector came from the same source. The boy and his younger brother found some long poles in the woods and used them to erect an antenna about sixteen feet high and forty feet long. A good set of phones completed the outfit and after some strained listening the boys heard a bit of code, but it was like a foreign language to them.

The next act was to purchase a vacuum-tube socket, a rheostat, grid condenser, variable air condenser, and a variometer. Dad made up a little unit containing the control for the detector filament, etc. Mother contributed a small table to put the apparatus on. A UV-200 detector tube and five flashlight batteries were then bought, the latter to be used as the 22½-volt B battery.

Dad didn't want an outdoor antenna, so it

was up to him to provide one in the attic. One night the two boys and Dad shed most of their clothes, donned overalls and climbed up through a trap door into the attic which was barely four feet high in the centre. A very few boards, nailed here and there over the joists which held the ceiling below, made a precarious

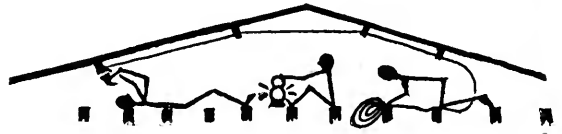

footing, or rather backing, for they had to move around on their backs most of the time. One boy held the lantern, the other held the wire, and Dad nailed up the insulators and fastened the wire; while down below the family dog, Jakey, cocked one ear aloft and looked as if he wanted to help too. Always afraid of putting their feet through the plaster, the trio wriggled and squirmed, pounded, puffed, and groaned for nearly three hours. When they crawled down, the attic was well dusted and they were fit only to get into the bath tub.

The next night Dad finished tacking the lead-in wire through a closet and along the baseboard of the boys' room to where the radio table was.

A kind neighbor came in with a spare A battery which he said they could use until they were able to get one of their own. This Good Samaritan brought a newspaper with him, which showed a diagram of the hook-up to be used. Dad was mighty glad that this was *the* hook-up, for he has always felt that there were as many hook-ups as there are radio fans, maybe more, for some fans seem to be constantly dopping out new ones.

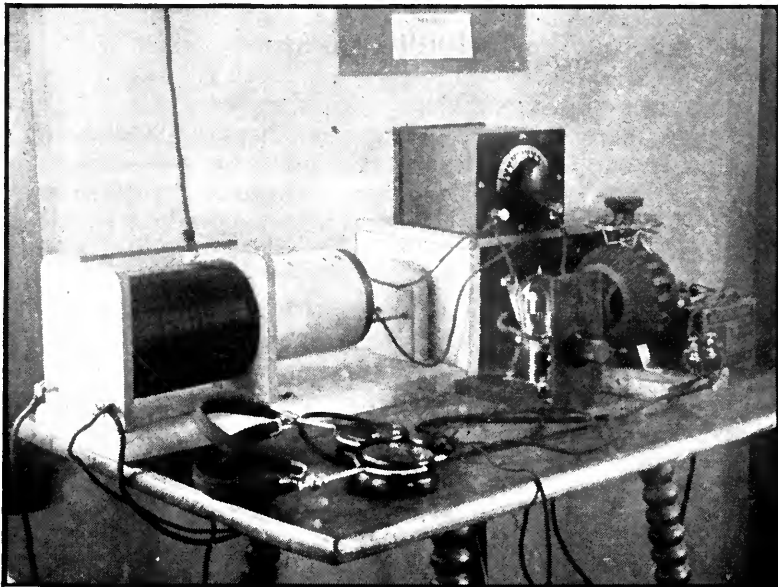

THE SET

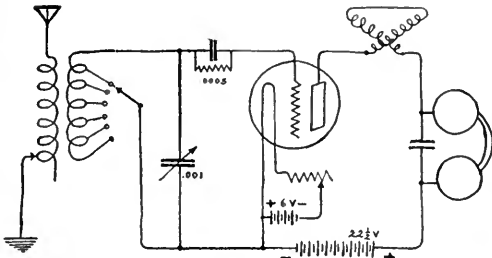

THE GOOD SAMARITAN'S HOOK-UP

When the stuff had been fastened to the table top, the Good Samaritan studied his treasured hook-up and fastened bits of wire here and there on the apparatus and finally connected it to the batteries. The ground wire was attached to a radiator. Then, oh critical moment, he put on his headset and began to move different things while he listened for something. The bulb lighted but it wouldn't talk. What could the matter be? Dad and the G. S. compared the hook-up with the different wire connections and found a disagreement between them. Changing the wires he listened again. Suspense . . . WAAJ! Hurrah! Twenty watts, eleven miles away and our set was getting it. Then he tuned in WNAC, Boston, and all hands called it a night and went to bed.

Two days later, Boy, Dad, and Company



STATES HEARD FROM WALTHAM, MASS.

picked up "the Voice of the Air" at WG1, Medford Hillside, Mass., and after more than two weeks heard WJZ and WOR in Newark, N. J. Then a few days later came KDKA, "the Pioneer Broadcasting Station," over in Pittsburgh, and oh boy!—what a queer feeling they had when they thought of its being so far away! Did you ever have that feeling?

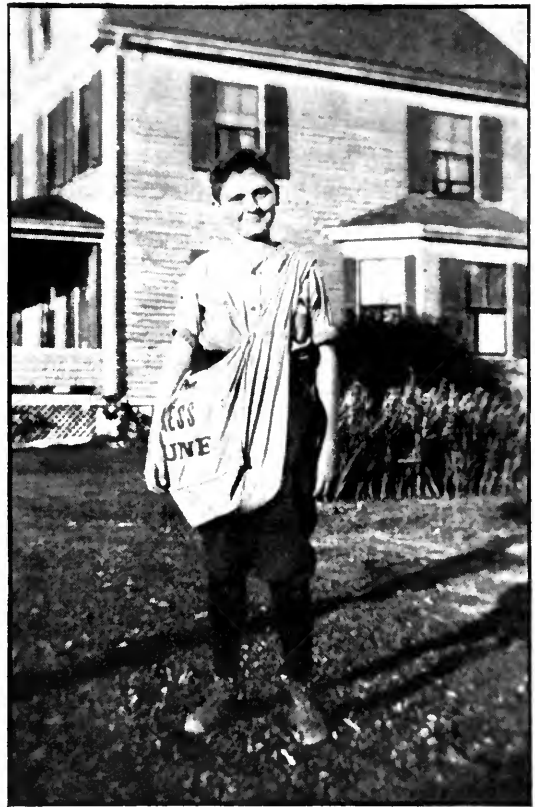

THE BOY

Dad was becoming handier at the tuning and he added WFAU and then WGY, "the Generous Electric Company" in Schenectady. Then, from the G. E. factory, he skipped over to school in Troy, WHAZ, and then back nearer home to WCN, Clark University.

Hearing about the electric light socket attachments that could be used for an antenna, the boy bought one and it has been in use ever since.

Don't forget that this was the boy's set, but Dad appointed himself chief operator and was on the job almost every evening. The younger lad contributed another pair of phones, so that by dividing up the ear pieces, four people could listen at one time, as shown in the etching of the family quartet.

The family next became acquainted with the great public-service company at WEA, New York City. Then up the Hudson a bit was WRW in that town which reminds one



THE F. Q.

of Washington Irving. Skipping east again they stopped to listen to WBZ, Springfield, and then a big jump south landed them with the navy at NOF in the District of Columbia. A step backward and they heard that noble organ at WOO in the store of one of the great merchants, in Philadelphia. Then one Sunday evening, faintly came the words, "WDAP, Chicago!" If getting KDKA had made Dad feel queer, think of his feelings now. He almost slipped off his chair, he was so excited. With his hands off the dials, there was silence, with his hands touching the dials came music from WDAP.

"Hello boy, wake up!"

"What's matter," muttered the boy.

"Got Chicago! Put the phones on and listen!" At this a sleepy boy rolled out of bed, slipped on the phones and heard Chicago while Dad held the dials. What bliss; and the boy had wanted to change the hook-up because for a long time we couldn't hear WJZ!

Skipping back to rugged New England they heard the voice of the Green Mountain State from WLAK; and then the Courier-Journal, WHAS, called then to Kentucky, the old hunting ground of Daniel Boone. What boy doesn't like to read about him? While they are thinking about hunting and Indians, Pontiac comes to their minds as they hear WWJ talking from Detroit. Back down in Philadelphia, another merchant announced WIP, further south they listened to WBT, in Charlotte, North Carolina. Returning a bit they heard "Hello Uncle Johnny, Hello Everybody" at Station WQAA. WRP in Camden, N. J.

reminded them of the school-days history of the Revolutionary War, and then in a few minutes they were on the banks of the Father of the Waters listening to the call of WOC, "Where the West Begins, and the Land

Where the Tall Corn Grows," and the name of a school having a queer name which they didn't understand.

They paused to breathe again, for they had broken their distance record. The next night from KYW in Chicago came the strains of that splendid grand march from the opera "Aida," played in the Chicago Opera House. The following evening they stopped in the midst of the machine tool industry and heard WLW, Cincinnati, Ohio. Skipping up to Buffalo

they heard WGR. WGM, "The Voice of the South" calling from Atlanta, Georgia, reminded them of Sherman's March to the Sea. Moving the condenser one degree carried them to a foreign shore, where a voice said, "Habana, Cuba." Shades of the buccaneers! Dad and his better half nudged each other and held fast.



An announcement in English and one in Spanish, then a fine piece of orchestral music followed by the call PWX, assured them that it was indeed a foreign land. Fifteen hundred miles away, and they could hear the talking and music.

Doesn't the wonder of it almost take your breath? Oh yes, they have a clock down at PWX and you can hear it tick.

The next evening the boy made his farthest West by hearing WHB, Kansas City, Missouri, in the heart of America.

Returning east once more the boy and his Dad heard WHN on Long Island. Next they were out by the Mississippi listening to KSD in St. Louis and were reminded of Churchill's story "The Crisis." Then the "Wave from Lake Erie," WJAX, broke on their ears and they remembered about the battle of Lake Erie which took place at Put-in-Bay, fifty or sixty miles west of Cleveland. Ever been to Put-in-Bay? There are some mighty interesting caves there and one of them is said to have been a hiding place of Perry's.



So they go, skipping here and there, making the acquaintance of places far from home, studying maps and listening to people whom they had never expected to hear but are usually glad to have heard. They hear the tum, tum, tum of the fox-trot, the melody of Grand Opera, a talk about the Everglades, politics, books, medicine, or clothing. All Dad knows about a boxing match came from a bout at Madison Square Garden. One night there was the story of the Creation told in an ancient Indian language so old that only one man in the world could now speak it. Subjects innumerable, and a whole education for those who have the time to listen.

Broadcast reception is very erratic. It is not always the powerful stations which have been heard through the greatest distance. One night they picked up WHAK, a twenty-watt station 570 miles away in West Virginia and the next night Dad listened to WBL, a fifty-watt station, 1545 miles away in Anthony, Kansas.

Do you who live in the Central States ever stop to think what a fortunate location you enjoy? You can just tune in to the different stations in every direction around you, while radio fans on the Eastern edge of the country can listen-in on only half of the horizon, for not many people have stations that can get Europe.

One night, the boy started for bed and some time later, Dad, not having heard the usual cheery "Good-night," went up to investigate. Lo and behold, the boy had a regular loud-speaker working. He was stretched out on two chairs, with his feet on the radiator, phones on his ears, sound asleep and snoring like a saw-mill.

Ma wanted to understand code and now each evening at supptime, while preparing the evening meal, she keeps one eye on the clock so as not to be tardy at the receiver when Uncle Jack starts sending slow code from WGI. Now, when Dad and Ma are listening to a concert and code comes slamming in to the exclusion of all else, Ma doesn't mind at all, but listens to the dah-dit-dah and smiles while Dad sits by in a spirit of resignation.

Did you ever have a radio ghost in your house? One night Dad was roused from sound slumber by Ma, who said, "There's a queer noise downstairs." Dad didn't hear anything for a few moments, then all at once there came the sound of a telegraph ticker; a few taps and then silence, a few more taps and silence. The boy had a practice set, but he was sound asleep, so Dad made a trip downstairs to investigate. On a table was a dry-cell lying near a telegraph ticker. Suddenly, while Dad stood still, looking and listening, the instrument began clicking. Not a hand near it. A few taps and then silence. Dad thought it about time for the ghost to go to bed, so he carefully looked the outfit over and found that while there was one wire connected between the battery and the ticker, the second wire was disconnected at one end but lying in such a way that a slight vibration of the building would cause the wire to make a contact and the ticker would momentarily operate. Removing the wires laid

the ghost, and Ma and Dad slumbered quietly the rest of the night.

Dad usually joins the boy at the radio set for a while every night before retiring. No matter how sleepy or tired he is, a few minutes' listening-in brightens him right up, but oh how aggravating are those faint indistinct announcements that can't be brought in! Just aggravating enough to make Dad want some radio-frequency amplification. You will see by the photo of the set that the controls are in such positions as to cause a great deal of trouble from body capacity. This was avoided to a certain extent by slipping a brass tube about two and one-half inches long over the detector bulb and connecting the brass to the ground wire. This arrangement made the set more stable, but several stations previously heard are now dumb, so Dad removed the brass tube in order to have another try at those stations. From the operation of the boy's receiver, Dad is firmly convinced that the best way to avoid trouble from body capacity is to use long shafts on the controls, preferably of nonmetallic material. A friend of Dad's extended the shaft of a grid variometer and placed on it a talking machine disc record for a dial. This arrangement gave excellent results as it avoided the body capacity effects, and the large dial gave a very sensitive control of the instrument, permitting the tuning-in of stations whose broadcast was formerly nothing but noises.

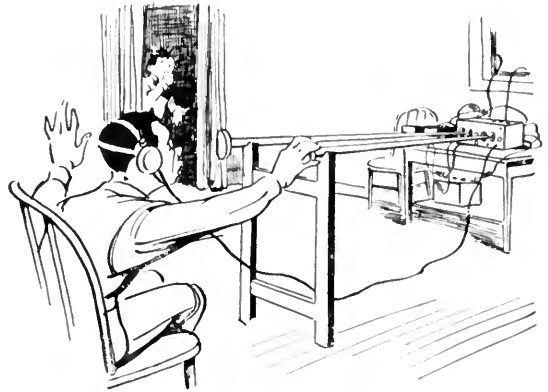

THE BEST WAY TO AVOID BODY CAPACITY

Of the calls heard, the worst mix-up was when two stations were alternating their programs and announcements: WHN, Ridgewood, Long Island, and WEAG, Edgewood, Rhode Island. The two kinds of wood and islands certainly had everyone puzzled.

# R. F. Amplification Without Distortion or Reradiation

By EDWARD LINDLEY BOWLES

Instructor in Electrical Communication, Massachusetts Institute of Technology

Many beginners have been intrigued by the claims made for various involved circuits. For the novice, radio frequency is complicated, and its use does not always result in greater range with a home-made outfit.

You will do well to attempt R. F. amplification only after you have mastered a regenerative receiver and A. F. amplifier. This is especially true since the change in the broadcasting wavelengths has been in effect, because few transformers will cover satisfactorily a range from 220 to 550 meters.

We do not wish to discourage the use of radio frequency, but we do wish to discourage indiscriminate buying which results in disappointment to the buyer and ultimate reduction of sales for the dealer.

—THE EDITOR.

**T**O-DAY the question of radio-frequency amplification is uppermost in the minds of both the amateur and the broadcast listener. Since the new allocation of wavelengths, the broadcast receiving set is not confined in its operation to wavelengths in the neighborhood of 360 and 400 meters, but it must range from as high as 550 meters to as low as 220 meters.

Volumes have been written on radio-frequency amplification, in which proponents of particular methods have been eager to convince readers of the merits of their choice circuits. Yet, many of those who have attempted to construct their own radio-frequency amplifiers for short wavelength work have been disappointed in the results. This is due to an in-

adequate knowledge of the functioning of the units employed, and the natural tendency to judge as "best" the circuits bearing high-sounding names and blessed with good press agents.

Many so-called radio-frequency amplifying transformers, or amplifying devices, which have been advertised for the shorter wavelengths, have proved to be poor. In fact, the writer has found that in some cases so-called short wavelength radio-frequency amplifying devices have done more harm than good. It seems only fitting that since radio broadcasting has reached a point where many wavelengths must be used in order to relieve congestion, and since these wavelengths must be "short," the broadcast public should have a general idea, at least, as to why there is likely to be difficulty in applying

only general ideas of radio-frequency amplification to circuits which they have already constructed or which they propose to construct, in order that these difficulties may be avoided.

Technical analysis has shown that R. F. amplification is more effective than A. F. in bringing in distant signals. Of course, if a signal is too weak, no matter how good the receiving set may be, the signal will not come in. In other words, there must be a slight disturbance, at least, in the neighborhood of the antenna or loop, in order that the re-

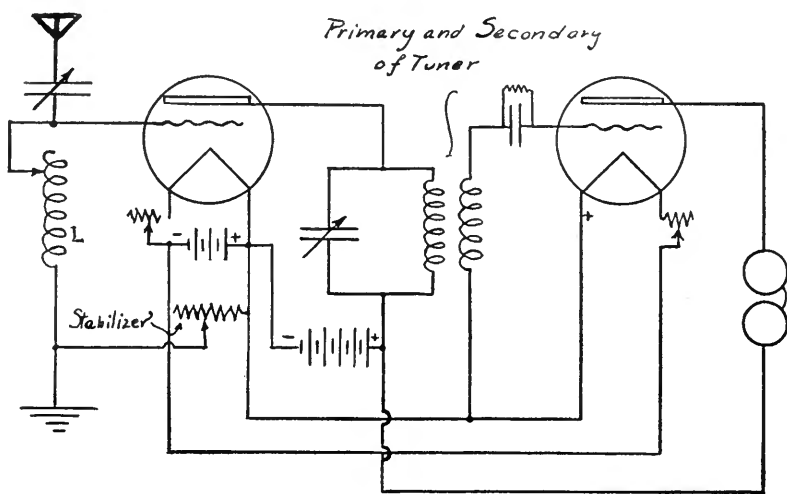

FIG. 1

R. F. amplifier showing a tuned primary transformer

ceiving apparatus may be affected. The antenna is capable of grasping more of the energy sent out in the form of waves than is the loop. As a consequence, much more amplification is necessary where a loop is used. In either case, where a single tube is used, and where signals are not coming in strong, or where distant signals can not be heard, one is confronted with the problem of introducing some sort of amplification. One can use audio-frequency—a common practice—or radio-frequency. Audio-frequency has, of course, become very popular, and many receiving sets are now equipped with a stage or two of such amplification. Two stages of audio-frequency amplification, a regenerative tuner, and a detector tube, make the most popular combination. If a loud speaker is used, the amount of energy delivered by the two stages of amplification is not always sufficient to operate, especially in large, open places, so that in some cases an additional amplifier, usually of three tubes, is used to furnish sufficient energy to operate the loud speaker diaphragm.

It has been shown by actual analysis that the detector tube is comparatively more sensitive when it is affected by a strong signal than when it is affected by a weak one. In fact, the effect which signals can produce on a detector is probably roughly proportional to their square. That is, if the intensity of the impressed signal is doubled, its effect will be quadrupled. It is evident, then, that any amplification of the incoming signal which can be made before it reaches the detector tube will have an effect far greater than the same amount of amplification of the signal after it has affected the detector tube. Roughly, a radio-frequency (voltage) amplification of 10 has the same effect as an audio-frequency (voltage) amplification of 100. It is for this reason that so much effort has been made to devise apparatus which would properly amplify signals at radio frequency.

The design of radio-frequency amplifying circuits for the longer wavelengths is a comparatively simple matter. The long wavelengths correspond to the lower frequencies, and it is much easier to build circuits to behave properly at low frequencies than it is to build them to behave properly at high frequencies.

Various radio-frequency amplifiers were discussed in two articles by Mr. Arthur H. Lynch in the March and April issues of *RADIO BROADCAST*. Ordinarily, tremendous amplification is

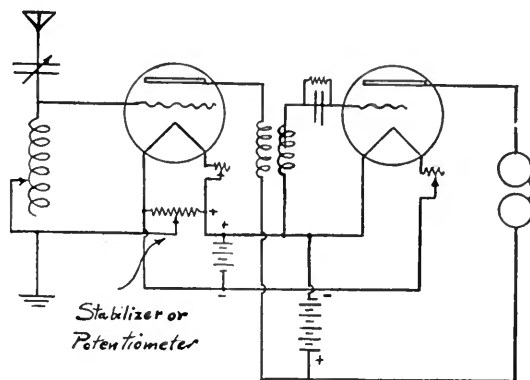

FIG. 2

An air-cored transformer-coupled amplifier with a potentiometer to control the R. F. tube

obtained by regeneration; and even greater amplification can be obtained by super-regeneration; but, at the same time, regeneration introduces distortion, and produces reradiation. Improperly adjusted regenerative sets may make a particular locality untenable for others who are attempting to receive, for the latter, in making their own adjustments, will be greeted with a series of variable howls and squeals which are anything but enjoyable. Regeneration can be used in conjunction with radio-frequency amplification, however, so as to prevent reradiation.

The greatest difficulty in radio-frequency amplification is to obtain this amplification without regeneration. Many of the coupled radio-frequency amplifiers for short wavelengths operate as regenerative circuits, so that after all, the amplification in this case is determined by regeneration and not by what we would ordinarily term direct tube amplification—due to the amplification factor of the tube itself. An example of a tuned radio-frequency amplifier, as produced by a commercial company at the present time, is shown in Fig. 1. This amplifier is constructed with a set of four output coils so that it operates at from 150 to 3,000 meters. The radio-frequency amplifier is coupled to the detector tube. The grid bias voltage is obtained by means of the stabilizer shown in the figure. This stabilizer makes it possible to prevent the amplifier from oscillating. When the arrow is at the extreme right, the grid of the tube is most positive, and when it is at the extreme left, the grid is most negative. As the arrow moves toward the left, the circuit is more and more likely to oscillate. A radio-frequency amplifier should operate with-

out regeneration and without oscillating. Those who have operated a regenerative receiver know that as the tickler is moved up to a certain point no sound is heard, but suddenly a definite point is reached where a click is heard in the telephones. This click is due to the fact

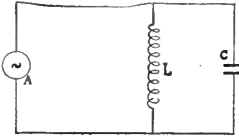

FIG. 3  
A schematic circuit showing how a condenser and an inductance in parallel may divide the current

that the tube has begun to oscillate at a radio-frequency. When the tube oscillates, the current furnished to the tube by the B battery changes and it is the change of this current through the receivers that produces the click. When the tickler is moved still further, another click will be heard. This second click indicates that the oscillations have ceased. In tuning-in a station, regeneration is obtained (if the setting of the tuner is correct for the particular station) just before the first click occurs. If a radio-frequency amplifier is oscillating at a radio frequency, this fact can be detected by touching the finger to the grid of the tube. If oscillations are present, they will be stopped by this act so that a distinct click will be heard in the telephones. This is not the proper state of a radio-frequency amplifier.

Fig. 2 shows a simple type of radio-frequency amplifier involving an air core coupling transformer. The operation of such a circuit is very difficult at short wavelengths because the tubes are almost bound to oscillate unless the potentiometers shown are so adjusted that the grids of the tubes are positive. When the grids are positive, the possibility of oscillation, and therefore of regeneration, is reduced, but it will usually be found that under these conditions the ordinary radio-frequency amplifier is not of much use. In other words, if the grids are made positive and then are slowly made negative, in the act of tuning, it will be found that the operation of the circuit will depend upon a critical adjustment of the potentiometers. This means that the circuit is operating on the border of oscillation; that is, it is acting as a regenerative circuit. This can be definitely determined by having the circuit in operation under such conditions and by sliding the potentiometer dial in such a position that the grid is as negative as possible (that is, by sliding the potentiometer to the extreme left in the

figure). Under these conditions, if the amplifier is oscillating, a distinct click will be heard on touching the grid connections of either tube.

The action of radio-frequency circuits may be understood more clearly by considering some of the units which make them up. For instance, a coil of wire in an electric circuit offers no more opposition to the flow of direct current (that is, current flowing in one direction only and interchanging in value) when the wire is in this form than it does when the wire is unwound. For currents which alternate in direction, the situation is different. The higher the frequency, the more opposition the coil offers to the flow of current.

Further, an electric condenser is made up of two adjacent conducting surfaces separated by an insulating material. It does not allow any direct current to pass through it, yet, if an alternating voltage is impressed on a circuit containing a condenser, the current which flows depends upon the frequency. The higher the frequency of the alternations of the impressed electric force or voltage, the greater the current. Short wavelengths correspond to high frequencies. For example, a wavelength of 300 meters represents a frequency of one million cycles a second. A wavelength of 100 meters represents a frequency of three million

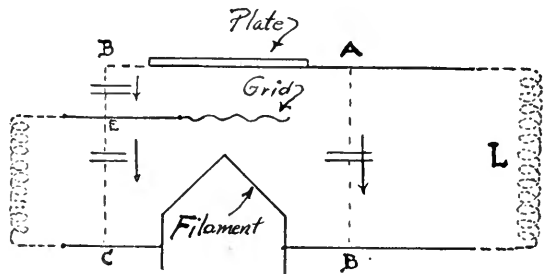

FIG. 4  
A schematic diagram showing the little fixed condensers which are present in every vacuum tube

cycles a second. Keeping these facts in mind, the result can be illustrated by means of the circuit shown in Fig. 3, where there is an alternating current generator capable of producing an electric force or voltage of any desired frequency. If the frequency is very low, all the current will flow through the coil L, for the lower the frequency the less will be the opposition which the coil offers to the flow of current through it. At high frequencies, the tendency of the current will be to flow through the condenser C, for the higher the frequency the



lower will be the opposition which the condenser offers to the flow of current through it. It is possible, then, to have a frequency so high that much of the current will be passed by the condenser C. When the frequency is such that the opposition offered by the condenser is practically the same as the opposition offered by the inductance, then the circuit is said to be in resonance. Such is the case, for example, when the parallel circuit of Fig. 1, made up of the condenser and inductance, is properly tuned to a particular wave.

A very small capacity may have a very harmful effect at high frequencies. In the case of radio-frequency amplification, the little condensers in the vacuum tubes themselves cause much mischief. Small condensers are formed by the grid and filament, and by the plate and grid, so that if we were to represent these little condensers on the outside of a vacuum tube, we would have a picture much like that shown in Fig. 4. These little condensers are capable of causing oscillations at high frequencies, for if a pressure exists between the points AB, it will not only send a current through the little condensers represented by the plate and filament, but it will also send a current from B to C through the little condensers represented by the plate and grid, and by the grid and filament, respectively. The current flowing through the condenser between E and C causes the proper kind of voltage to be impressed on the grid of a tube to produce an oscillating current in the plate circuit, if the plate circuit contains a small amount of inductance, as shown. Usually the grid circuit also is tuned by an inductance, as shown by



FIG. 5

A recently developed set of the Clapp-Eastham Company, having one stage of R. F., detector, and two stages of A. F. amplification

the dotted line. This aggravates the tendency for the tube to oscillate. Therefore one may construct a radio-frequency amplifier with apparently no condensers, and yet the amplifier may oscillate and give no results whatever.

Tuning the transformers of a radio-frequency amplifier has the effect of building up parallel circuits of capacitance and inductance eager to oscillate, but in the receiver illustrated in Fig. 5, this tendency is curbed as shown in Fig. 6.

The tuning element consists of a series antenna condenser C1 in series with a variometer V. The first tube is used as a radio-frequency amplifier, and it is coupled to the detector tube by means of a tuned primary radio-frequency transformer which is prevented from oscillating by means of the control condenser C2. This little condenser is a variable of about .0002 mfd. capacity. The primary of the radio-frequency transformer is tuned by means of

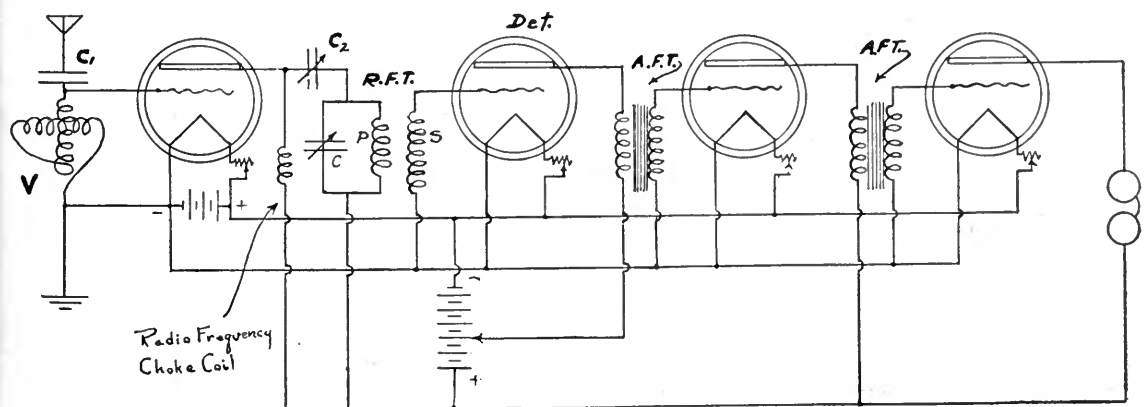

FIG. 6

Wiring diagram of the set shown in Fig. 5. The oscillation condenser is shown as C2. Note that the B battery feeds the plate of the R. F. tube through a choke-coil

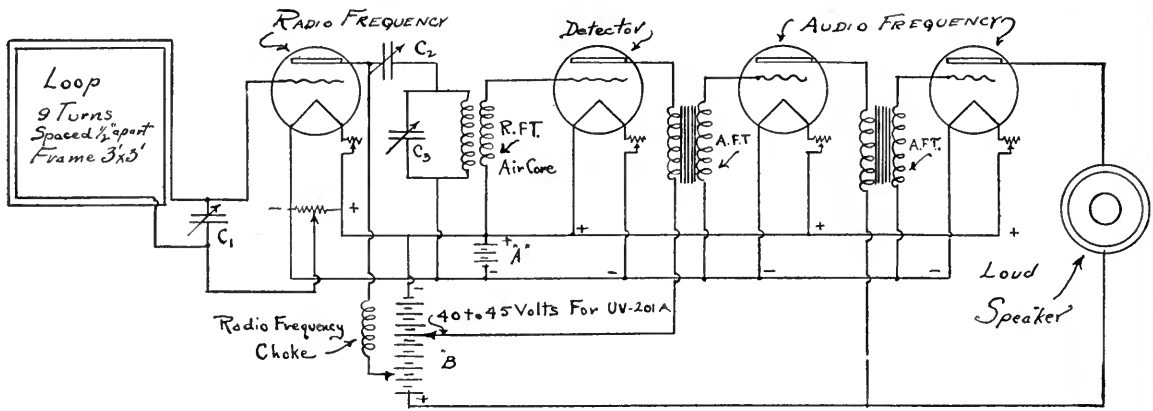

FIG. 7

A suggested hook-up. The oscillation control condenser is shown as C2. Note that there is no grid condenser or grid leak

the condenser C3, which has a maximum capacity of .001 mfd. The secondary of the radio-frequency transformer is not tuned in any way, but it is connected directly to the grid of the detector tube, as shown. The control condenser in the plate circuit makes it necessary to furnish the B battery voltage to the plate through the radio-frequency choke shown. This is an iron-cored coil. No grid bias is used in this set and there is no stabilizing device such as a potentiometer. It is interesting to observe that the detector tube contains no grid leak or grid condenser. The designing engineer for this company has found that the insertion of the grid leak and grid condenser in the set actually hinders its operation.

The detector tube works with two stages of audio-frequency amplification, as shown. These are of the usual form. The dial marked "Osc. Control" (Fig. 5) operates the condenser C2 (Fig. 6). The dial marked "antenna inductance" operates the variometer V, and the dial marked "radio-frequency control" operates the condenser C3. These dials are unique in that they operate at all times with a micrometer adjustment; that is, the knob makes several revolutions in order to advance the dial through its full scale. The condensers C2 and C3 are so arranged that the shaft supporting the moveable plates, and running to the knob, is always farthest from the plate side of the condenser; that is, it is always at the potential nearest that of the filament. In this way, body capacity effects are nearly eliminated.

A variation of this circuit is shown in Fig. 7. In this circuit a loop is used in conjunction with a small tuning condenser C1. The control

condenser is shown as C2, and the transformer tuning condenser as C3. The radio-frequency transformer may be made up of cardboard tubes. Bakelite apparently does not work as well under ordinary conditions. The two windings may be placed one inside the other, as shown in Fig. 8. The inner winding may be used as the primary and the outer winding as the secondary. Both coils should be wound in the same direction. They can be made up with ordinary cotton covered or enameled wire of from Nos. 22 to 26. The primary should have comparatively few turns compared to the

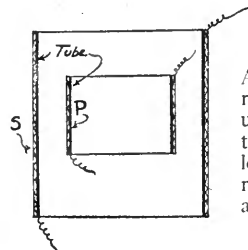
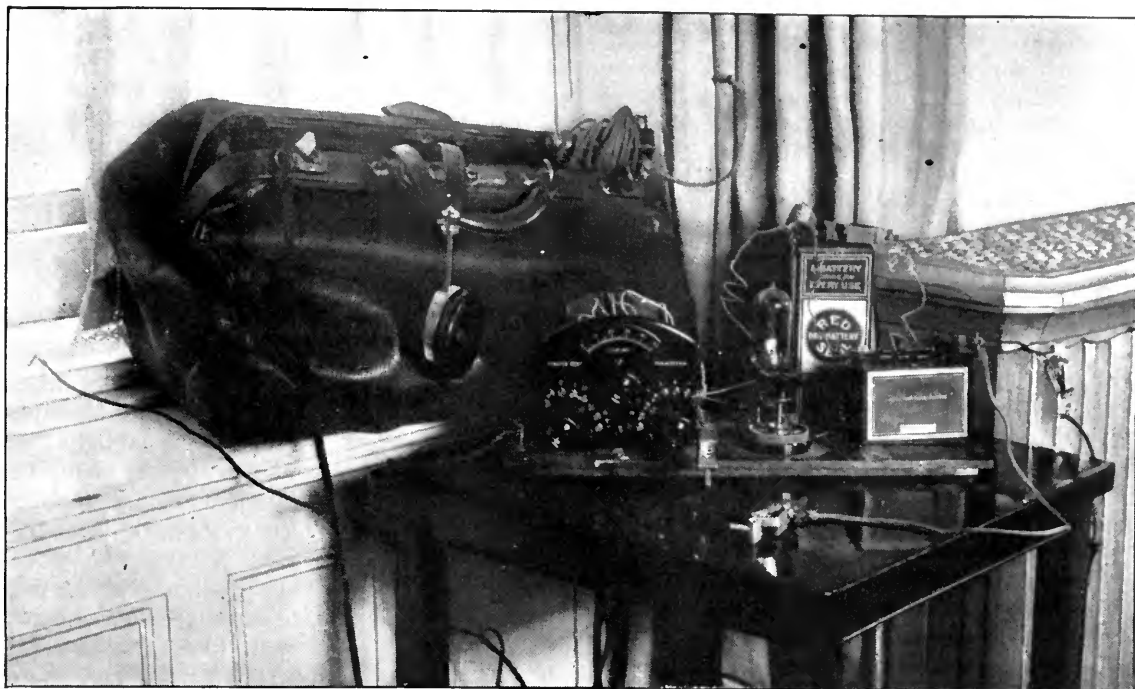

FIG. 8

A cross-section showing the arrangement of the coils that make up the primary and secondary of the R. F. transformer. The two lower leads should go to the filament and B battery if both coils are wound in the same direction

secondary. The exact number can be determined only by practice. Roughly, from 30 to 40 turns on the primary and from 75 to 100 turns on the secondary will probably give good results if the ratio of the diameter of the primary winding to that of the secondary is about 0.6. The radio-frequency choke may consist of an old primary of an audio-frequency amplifying transformer or any iron-cored coil of only a few layers in which the wire is not too fine.

This set is subject to almost perfect control by means of the series plate condenser C2, and with it, radio-frequency at short wavelengths is very satisfactorily accomplished.



© Clinedinst

#### IT DOESN'T TAKE LONG TO GET IT HOOKED UP

At the left is the antenna wire, flung out of the window, and at the extreme right, the ground connection on the radiator. The plug and roll of wire in the jaws of the traveling bag are an alternative aerial appliance

## A Portable Set for Lonely Hotel Hours

By J. T. N.

SOME cynical person has said that love of home is chiefly expressed and upheld by the homeless. However that may be, I am one of those to whom days and nights at home are a luxury, and days and nights in hotels the all too common experience. To relieve the monotony there have been always, of course, various expedients, theatres, movies, books. None, however, as good as modern radio. At least I find it so. I am often too tired for theatre or movies, even if there is an attractive offering. Also my mind is generally too full of the day's work to favor the concentration necessary for profitable reading. Radio makes fewer demands. No matter how tired or preoccupied, you can listen. Sweet voices sing for you, bands play, violins, horns, orchestras, organs. Besides there are frequently broadcasts of banquets and public meetings. Even lectures and speeches do not tax your tired energies

when you know they can be turned off without disturbance (or discourtesy) the moment they fail to hold the attention.

The advantages of radio under such circumstances are obvious enough and do not require elaboration. My purpose here is to tell how I manage my hotel radio.

My method is simple. After years of experience in regulating luggage—the problem is to carry all one needs but not a scrap more—I have settled down to a suit case for clothing, a small bag for toilet articles, pajamas, books, etc., and a brief case for documents. The brief case frequently travels in the suit case, leaving only two articles of hand luggage. To add radio to the outfit was more or less disconcerting to one of settled habits. I considered having a small case made the size of a set, with the panel just inside the lid. But at best this involved a third thing to carry and a fourth when the brief case could not go inside. So I

rejected the idea of radio in a separate case. I then tried packing the essentials of a hook-up in the suit case, but they would not stay put, and the result was a mess, involving poor radio, because of loosened joints and fittings. Finally I decided to get a larger hand bag to substitute for the small one carrying toilet articles. I selected one with a fairly wide bottom and ample jaws. On a board or base a little smaller than the bottom of the bag I fastened a vario-coupler, a WD-11 tube socket, a small rheostat, a combination grid-condenser and *variable* grid leak, and four small binding posts. These I screwed down securely wired with the shortest possible leads. All connections were well soldered. To the most convenient negative A battery lead, I soldered short, flexible insulated wire terminating in a strong battery clip and added the same equipment for the positive A battery lead and the positive B battery lead. (In my hook-up, as will be seen,<sup>1</sup> the negative B battery lead connects with the negative of the A battery, and consequently this is not a part of the fixtures on the board.) I also soldered a short, flexible wire terminating in a battery clip to the plate lead. This is for connecting the phones. The outfit thus assembled goes to the bottom of the traveling bag. It is not much of a nuisance there as it is all firmly put together. The vario-coupler is a commercial unit already equipped with dial, switch lever and points, fixed on a little panel of its own. Into the bag, in convenient corners, I also tuck a roll of about fifty feet of No. 18 stranded flexible insulated wire, a small 22½-volt B battery, another roll of about ten feet of the same wire with battery clips on both ends, a short wire similarly provided, a pair of head phones, and (in case it is best to use it for an aerial connection) a radio plug for an electric light socket, with about fifteen feet of flexible insulated wire attached, terminating in a battery clip. I carry also two WD-11 tubes, one for use and one reserve against a possible blow out. I have as yet no satisfactory place to carry the tubes and they go in the suit case cushioned by the wearing apparel. But this is a poor makeshift. Some sort of a small box, padded and partitioned,



would be the thing, but I have never happened on one so far.

There is nothing peculiar about the hook-up I use and doubtless it could be improved somewhat so as to give even better results. However, I would reject any modification which called for more parts, as I now carry quite enough miscellany in that bag. (My wife occasionally inspects it with expressions of horror.)

One who lives much in hotels learns to adapt himself to circumstances. To have radio in a hotel it is necessary to call upon this acquired aptitude. If I arrive in daylight (and as well as I can anyway) I inspect the environment before registering. To the room clerk I probably appear rather a fussy old gentleman, possibly slipping into a paranoic state with fixed ideas, obsessions, violent likes and dislikes. Or he may be "on." These hotel

clerks know a lot they say nothing about.

I show marked preference for rooms at the top. I like them at the front, or at the rear, or at the side, *as the case may be*, and in each case I am very definite about it. (It depends on where I saw the telephone and telegraph wires, the trolley lines and the near by or connecting buildings). I am apt to inquire casually about the construction of the building. Old hotels are best. They may burn you up, but in the meantime the radio will be better. No metal construction, of course, is the reason. Also I have a weather eye out for the hotel detective. I do not intend to violate any rules, but if he subsequently thinks my wire (if I use it) is intended to facilitate an escape without paying my bill, I want to explain before he insults me.

Having done as well as I can in the location of my room, I inspect its interior. A glance takes in windows, ledges, available ground. Radiators are usually all right for that; maybe bathroom connections are better, but I seldom use them as they are inconveniently placed. Recently in an overcrowded hotel where I had to grab anything I could get, the room had no bath and no radiator. It was in the South. I used the electric light wires there for the aerial and was puzzled what to do for ground. Finally I fastened the ground wire to the bed springs. It worked beautifully. I'd heard of bed springs for aeriels but not for ground. (It

<sup>1</sup>J. T. N.'s hook-up is practically the same as the "Parker" circuit. This is shown in Fig. 1, page 230, of this issue.

would be a counter-poise doubtless.) But I cannot claim a discovery, for the bed spring connection fell off and the reception went on without any change whatever. This was one of the old hotels, God bless 'em, no steel construction nor reinforced concrete.

Where it will work, and usually it will, I prefer to drop my fifty-foot wire over the window sill. I select a small table, move it over by the window, take out my outfit, throw out my wire, and clip my ground wire to the radiator. One telephone lead I attach to the plate circuit by letting the clip bite it, and the other telephone lead I insert directly in the proper tap of the B battery. My short double clipped wire connects B minus with A minus. I forgot to tell about the filament battery. I exclude it from my outfit because dry-cell batteries are purchasable at all hours and at low cost in any city.

If the outside wire will not work or conditions will not permit its use, I try the electric light connection. I have never had any real trouble. Most cities have local broadcast stations or are near some other city that has. Sometimes those near enough for my single tube and more or less haphazard equipment operate only semi-occasionally or on restricted

schedules which do not match my hours of freedom, but I seldom fail to find real entertainment ready at hand. Even if broadcasts are lacking there are near by amateurs handling "traffic." One lulls a child to sleep with monotony and repetition. The c-q-ing of the amateurs has a similar effect, and I am apt to grow drowsy. Well, that was what I wanted, wasn't it?



© Clininst

A WELCOME RELAXATION, AFTER A DAY OF WORK AND TRAVEL  
The portable apparatus in action at the Shoreham Hotel in Washington

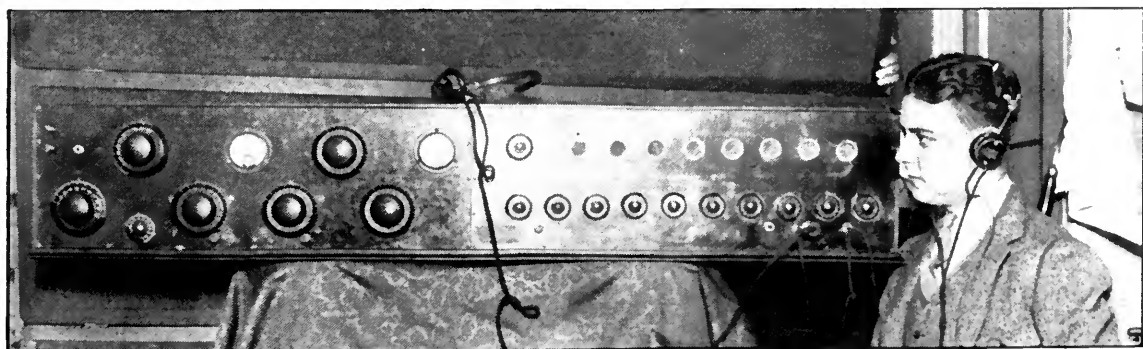

THE 10-TUBE SUPER-HETERODYNE SET WITH WHICH R. R. MAYO, WHO BUILT IT, HEARS EUROPE REGULARLY

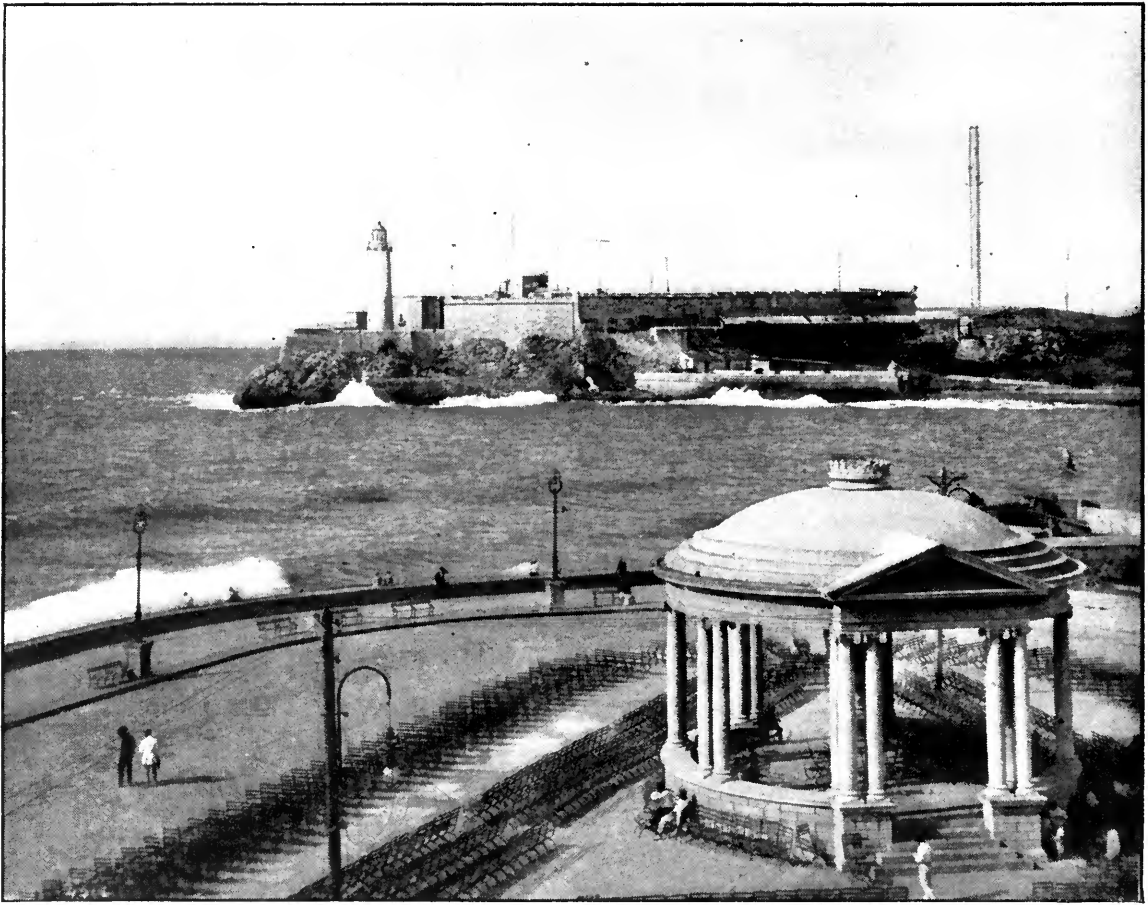

AT THE FOOT OF THE PRADO, HAVANA

Where Cuban beauties and beggars share the moonlight and the music, while the light on famous old Morro Castle winks first at them and then at the men who go down to the sea in ships

## A Millionaire's Cruise on an Operator's Pay

By A. HENRY

Yachting on \$40 a month is possible only for radio men (and not always for them!) In this article—the fifth on the subject of “Operating as a Career”—Mr. Henry shows us further lights and shadows of one of the most fascinating jobs in the world.—THE EDITOR.

FOLLOWING my dismissal for having missed a vessel sailing for Nova Scotia, you may imagine my surprise when I was told by the Superintendent that my case had been reconsidered and that he was pleased to offer me a fine assignment. After dilating upon the wonderful cruise the yacht was to take, it was no

longer necessary for him to “sell” the job to me. As advertising men say, I was completely “sold.” Before letting him know this, however, I went through the business of showing indifference and mentioning an assignment promised me by a competing company in the approved manner. Yes, I secured the raise.

The reason for my being selected was that a

radio outfit had to be installed on the particular yacht which I was to meet at Key West, and I had done a similar job on the *Wakiva*, down in Tampico. The equipment had been on its way a day or two and they were anxious to have me follow as soon as possible. A steamer was leaving New York in two days for Key West and I would have to take it and stay at a hotel there until the yacht came in. Well, you can imagine how my adventuresome nature responded to that! One does not care to abandon the winds and snows of New York in February for the sunshine and flowers of the tropics, but—I permitted myself to be persuaded.

Oh, those days when one is foot-loose and fancy-free, gloriously young and satisfied to be off in a balmy, spring climate, bound for nothing more definite but nothing less exciting than Travel and Adventure! In Key West, the world smiled and I smiled back, ready to

lick the world or to make friends with all of it at a moment's notice. The best of everything was none too good to suit me and the worst was none too bad to bother me.

During the five days at Key West, following a delightful trip on one of the Mallory liners, I lived at the best hotel in town and casually mentioned to one or two of the gentlemen with whom I became acquainted that I was waiting for my yacht and that we were going to take a cruise around the West Indies; whereupon I found that even Key West has its financial pirates. One man of about middle age decided to take me under his wing and show me around. He dined me and would have wined me, but I did not indulge at the time. He was a very smooth article and kept me busy making evasive answers to his pointed questions concerning my finances, family and the like. He unfolded a great plan for making a fortune in a jiffy and let me know from time to time that he had



HINDU SNAKE CHARMERS AND FAKIRS AROUND IN PORT OF SPAIN

The weird music of the pipes of these snake-charmers in Trinidad is of a variety never to be forgotten

confidence in me, sought my judgment, as it were, and almost succeeded in swelling my head beyond the limits of the Panama hat I had purchased. My wardrobe was complete enough to allow me to accept his invitations to a dinner or a dance at this home or that club. Key West, in short gave me a reception that was not half bad. I was alluded to as a friend of the Duke of Sutherland, a claim I had never made, but didn't deny because I didn't have the heart to ruin all the fun these folks were having entertaining a "friend of the royal family."

Many of them begged me to offer the Duke free reign in their homes for the time he was to be in Key West; several tried to coax me to give up my room at the hotel and accept their hospitality during my stay. In saying that I knew the Duke would be grateful for their kind offers, but that I felt sure he had made arrangements which it would be difficult to change, I felt that the truth was not being transgressed; and my thanks for the offer to me was always followed by a refusal.

Mr. Van Wicklen, the financial gentleman, soon took it upon himself to ward off any more such offers for me, saying that he was entitled to first consideration and that I had repeatedly refused him.

Eventually the yacht came in, and by dropping out a back window of my hotel and going down the fire escape I managed to evade the few who had come to have me take them aboard the yacht. I hired a launch to go out and introduce myself to the Captain. As we drew up to the port gang-plank, another launch left from the starboard side, and from a vantage point on deck I saw the Duke and Duchess of Sutherland leave for the shore and to take a train back to the North. That is as near as I ever came to those good people. To my great relief, I found from the Captain that we would tarry but a few hours in Key West. We were to wait for the Count and Countess Szechenyi, who had chartered the yacht from the Duke. It was well for me to begin immediately to install the radio equipment.

The Captain and I went over the vessel to-

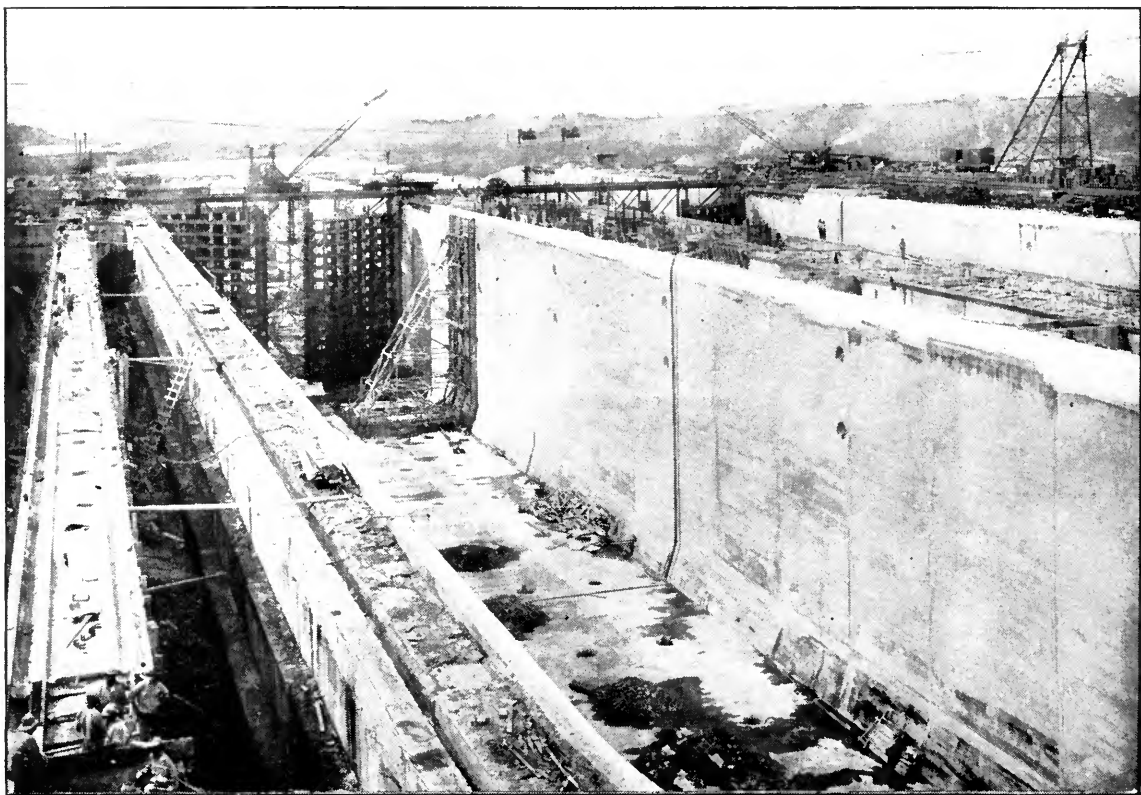

ON THE HIGHEST OF THE THREE LOCKS AT GATUN, PANAMA

Where American engineers fought every form of tropical disease in completing one of the largest "jobs" the world has ever seen. The Chagres River may be seen in the background. Just beyond the farthest horizon lies the Atlantic



gether looking for a suitable room to use for the purpose. A chat with the Chief Engineer, a good-natured Scot, revealed that the ship's generator was rated at 5K. W. and delivered a voltage of 35. Great Caesar's Ghost! I saw my trip being taken away from me. Someone had bungled—for the outfit I was to install was designed for use on 110 volts and even though the voltage had been correct, the poor little dynamo on the yacht could never have stood the load. There was only one thing to do and that was to get the ten-inch spark coil from the radio school at Key West and use it to transmit. The local manager refused to let me have it, however, and it was too late to get anything from New York. I visited several amateurs in an attempt to purchase a transmitting outfit, but could find none that was powerful enough.

All that day, with the assistance of the local manager, I worked erecting an antenna and installing a receiving set. That night I had something to tell the Captain confidentially. He agreed to the plan I unfolded, put two men in my charge, and sent us ashore in the tender. Once ashore we made for the radio school, and cracked a pane of glass out of a window, which we then unlocked. One man climbed through and it was then easy to open the automatic lock on the door and let the rest of us in. With the aid of a flashlight we found the object of our search, the treasured coil, and wrapped it up in burlap.

Then we returned to the yacht. It was an easy matter to put a sending key in series with the electric light line to operate the coil and there we were, all ready to go. I went to bed—and the next morning, when I woke up, we were in Havana Harbor.

During the day I was too busy shopping for



#### WHEN YOU STAND ON MORRO CASTLE

On one of those brilliant, peaceful, tropical days; with the Cuban flag snapping in the breeze above you and small craft cutting the blue Caribbean far below—it comes over you with a thrill that you wouldn't be anywhere else and you wouldn't change jobs with *any man*

white uniforms to reflect much upon my recent activities, but in the evening when I had a chance to review the past week, I wondered what had happened in the radio school when they found that the place had been burglarized. I chuckled as I wondered what Mr. Van Wicklen said upon finding that the Western Union messenger had paid my bill at the hotel and ordered my luggage sent aboard the yacht.

Havana Harbor and Havana! I thought of all the stories I had read and heard of that wonderful city. Many a time and oft had my algebra teacher held me up to ridicule before the class for reading a book of travel held between the bottom of my desk and my knees, instead of paying attention to a dissertation on

the value of X. I'm afraid X never appeared very valuable to me. Some of the tales I had read must have been written many years before, because I found it difficult, when traveling about the city, to locate any of the haunts I had read about.

The Chief Engineer's son was a chap of about my own age, and we went out to see Havana together. A military band played in the Plaza that night and a cosmopolitan gathering walked and talked and listened with languorous enjoyment.

We walked down the Prado, where Cuban beauties strolled in grandeur, for the edification of us passers-by, and the children amused themselves with roller skates and velocipedes. We dropped in at a cabaret called "The Black Cat" and saw, among others, a great many Americans of the race-horse-following variety. Then we sauntered on to the bandstand where a great crowd sat in the moonlight and listened to the music. Flivvers and limousines whizzed by; voices sang or called out gaily; and small craft made their way in and out of the harbor. No worry, no hurry—nothing to do but take in everything with grateful eyes and ears—and be glad to be alive.

On our way back we stopped in a soft drink establishment and watched a native skin a pineapple, cut it in chunks, put it in a thing that looked like a chemist's mortar, beat it to a pulp and strain the juice off into glasses for us. It was delicious. To attempt to tell you of the wonderful sights of Havana, from the Country Club to the race track, from Miramar to the Municipal Wharves, would be foolhardy. I think you'll have to go there. . . .

Following our two days' stay at Havana, we went around the north coast of Cuba to a small town called Nuevitas. We were told that tarpon fishing in Nuevitas Bay was good. It certainly was. Even as a schoolboy, I could never wax enthusiastic over fishing, for there never seemed to be enough action in it, but there is fishing and FISHING. In Cuba I was given a taste of the latter.

At night we hung a cluster of lights over the rail near the gangway, then threw bits of meat and bread into the water. In a few seconds what appeared to be dozens of large silver-hued fish were scrambling for the food. When they gathered in numbers this way, one of the quartermasters would hurl a harpoon at them.

Every hurl usually meant a fish. But catching fish is one sport, and catching tarpon is another. With a harpoon right through one of them he would swim first in one direction then dart in another, then shoot six or eight feet in the air, going through all sorts of contortions to break away. Some of them would bite fiercely at the bronze cable that held the harpoon to the line. A large tarpon would require two or three men to pull him in unless he was "played" and playing such fish with a line and rod is a very, very different game from snagging sun-fish with a worm and a bent pin.

After a few days' sport at Nuevitas, we dropped in at Jacmel, Haiti. We were going to go to Port au Prince but an insurrection there caused a change in our plans. Anyway, it could hardly have been more interesting than Jacmel. Voodooism is still an active cult among the Negroes of Haiti, and a part of the ceremony connected with this particular form of worship includes offering an occasional human sacrifice. One of these celebrations, if you will, was well under way when we arrived.

Those engaged in the festivities were bedecked in all manner of weird costumes. Nondescript and informal paraders followed a number of seemingly self-appointed leaders in a riotous march through the rows of huts that made up the town. Each of the leaders carried a large staff, dangling from the top of which was some part of the sacrificed unfortunate's body.

Jacmel is on the slope of a hill and is one of the dirtiest places it has ever been my privilege to see. Open sewers ran through the main streets and—but what's the use! I'm afraid Jacmel cannot be remembered as being particularly fragrant.

Our next stop was made at Kingston, Jamaica, where one could not help being impressed with the tropical beauty that makes so fitting a frame for the spotless city that a few years before had been wrecked by an earthquake. Our tender slipped alongside a little wharf at the foot of the public market and we were immediately surrounded by a crowd of Negroes who beamed at us as they offered mangoes and alligator pears (that is not the correct name, but it is the one most used) and tobacco made up into rope, and strings of bright colored beads made from berries and beans. These Negroes, who spoke with a pro-



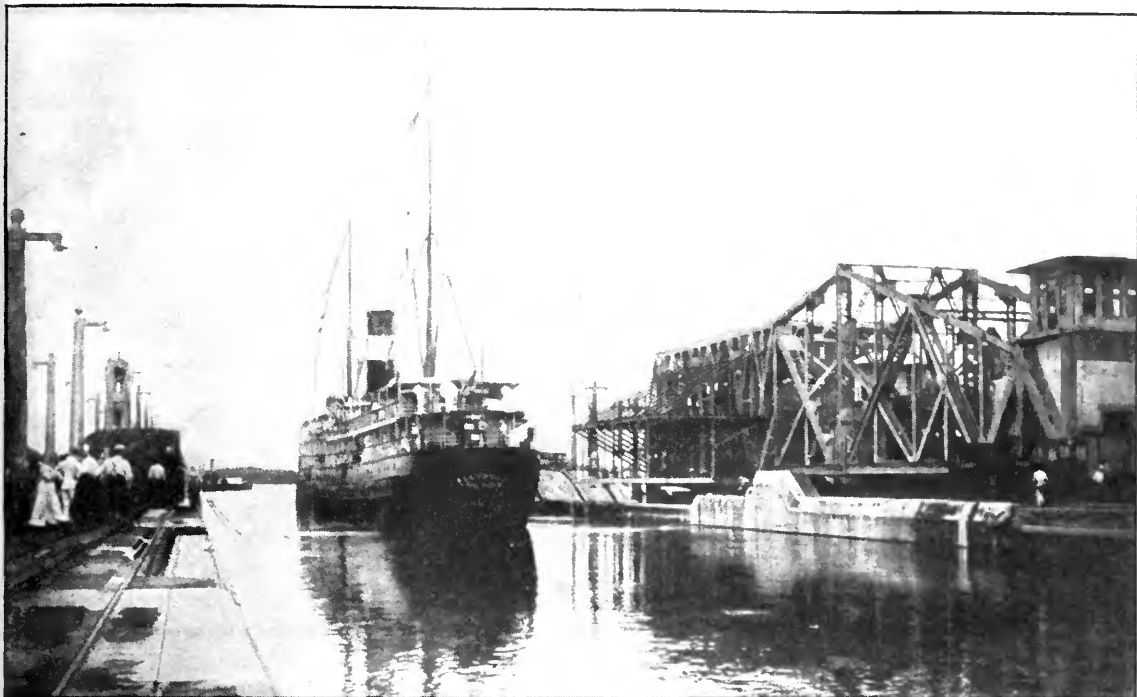

THE ALLIANCA—FIRST LINER TO GO THROUGH THE GATUN LOCKS

"Although you may not recognize me," writes Mr. Henry, "I am on the boat deck in the picture—sailed a few months later on this cruise as operator. We have let go the lines from the 'electric mules' and are headed for Gatun Lake"

nounced English accent, were politeness personified, despite their attempts to sell us more than we could carry.

But in telling you of this trip I have failed to mention the fact that I did a certain amount of radio work. Among other things—very few others—I copied press from the German station at Sayville, Long Island (SL) each night and banged it out with a few carbon copies on a Corona borrowed from the Countess. The time signals from NAA, Arlington, were a revelation to the Captain, and he was delighted to have the weather reports which came in twice a day. In mentioning the radio outfit, I cannot refrain from telling you of a record made with that purloined ten-inch spark coil. To my knowledge, it has never been beaten and is seldom approached. While we were in Santo Domingo City, the Count wanted to arrange for a railroad car for some friend, and requested a message sent to that effect. The radio station at Santo Domingo (SD) was out of commission at the time, owing, I was informed, to an enterprising operator's having departed with part of the equipment—and after attempting to reach Guanica, Porto Rico, without success, I was surprised to hear P,

the old spark station in the Isle of Pines, south of Cuba, tell me to go ahead with my message. I did, and he sent me an OK. In a few minutes I heard him send it on to M (Morro Castle, Havana), but I could not hear M. The air-line distance to the Isle of Pines was 480 miles—a long way to bat with a ten-inch coil and a crystal receiver, *in daylight*. That night the reply to the Count's message was among those sent broadcast by SL.

Upon leaving Jamaica, we went north again, as far as Santo Domingo City, and arrived just in time to witness the annual ceremony at which the natives carry the bones of Columbus through the streets.

In mentioning the next few places we stopped, it may be well for me to quote a letter from Rosea, Dominica sent while making the cruise:

You must be having a wonderful time with all the trolleys and traffic tied up by snow. Last night I received a report from Sayville, saying that you have had the worst blizzard since 1888. Here the summer attire we are now wearing is frequently too heavy for comfort.

We stopped in at Basseterre, St. Kitts, long enough to have a look around and mail a few post cards.



BALBOA'S PACIFIC, FROM THE SUMMIT OF ANCON HILL ABOVE PANAMA CITY

Just to the right is the Pacific entrance to the Canal. Mr. Henry says he will never forget this scene; and the incident of the flag-pole, which he describes, tells one reason why

Then followed a glorious run through the Virgin Isles. These islands are composed of lava and brimstone thrown up by some volcano, now extinct or sleeping.

Every time we set foot ashore, we are set upon by a band of blacks who hover around, begging pennies. I don't wear a uniform or carry a sign, but someone in the band is bound to single me out and tell me they have some nice things to show the "wireless." The "nice things" they have to sell usually amount to little more than a few woe-begone post cards or a poor-grade Panama hat.

From here we go to Martinique, St. Lucia, St. Vincent, Grenada, Trinidad, La Guayra, and Curaçao. With such an itinerary before us I can't help feeling like a millionaire—this is the life.

And it *was* the life!

Each one of the islands and towns had an individuality, but the one that made the great-

est impression upon me was St. Pierre on the island of Martinique, for here twelve years before, fire and brimstone from an active volcano had wrought havoc with the little town. Many of the battered walls were still standing. Great crevasses could be seen in the hillsides, caused by the burning lava as it flowed toward the sea. The natives tell of three vessels, lying at anchor in the harbor when the eruption took place, which were demolished, and how at certain times they appear again in phantom form, lying at anchor in the harbor.

One incident, which you will agree is enough to stick in a fellow's memory, occurred in Fort de France. Several young natives had paddled their little boats out to where we were at anchor, and we had been having great sport watching them dive for coins thrown into the

water. The water was so inviting that I decided to have a little swim myself, and inasmuch as my clothing was light, I dove right off the gangway and was soon having as much fun as the little coal-black roses. My attention was attracted by several people on board rushing to the rail, shouting and gesticulating wildly. I thought something had happened on the ship and that I was wanted in a hurry, so I made for the gangplank. As I approached it, two sailors who had rushed down, grabbed me by the arms and whisked me out of the water. I looked back into the water and saw several huge shark-fins in silent retreat.

Following a short stay at La Guayra and Curaçao, we went to Colon, Panama. There we had a mighty fine look at the greatest engineering undertaking in the world. Little did I imagine at the time that a few months later it would be my good fortune to be on the first ocean liner to pass through the Gatun Locks.

In Colon, I met a friend who was Radio Officer on a Panama Liner and he arranged for a railroad pass to Panama City for me. Among a million and one other things I saw the locks

at Mira Flores and Pedro Miguel and climbed up Ancon Hill, which is just above Panama City. Not satisfied with the wonderful view of the city and the canal and the Pacific that this vantage point offered, I climbed to the top of a topographical tower and then shinned up the mast to the cross tree, used to hold the red cloth marker. When I had almost reached the top, the mast snapped, and I fell to the upper platform, suffering no further injury than a huge rip in the seat of my trousers, which had caught on the projecting part of the mast. A pair of khaki trousers from a local shop relieved the only embarrassment caused by the fall.

From Panama we made another stop at Kingston, to take on coal, and then returned to Key West by way of the south coast of Cuba. Here, I dismantled the radio equipment, returned the coil I had stolen from the school there and said good-bye to the good yacht *Catania*.

The only people in the world who can take a trip of this sort are millionaires and radio men. The radio game is surely worth the candle.

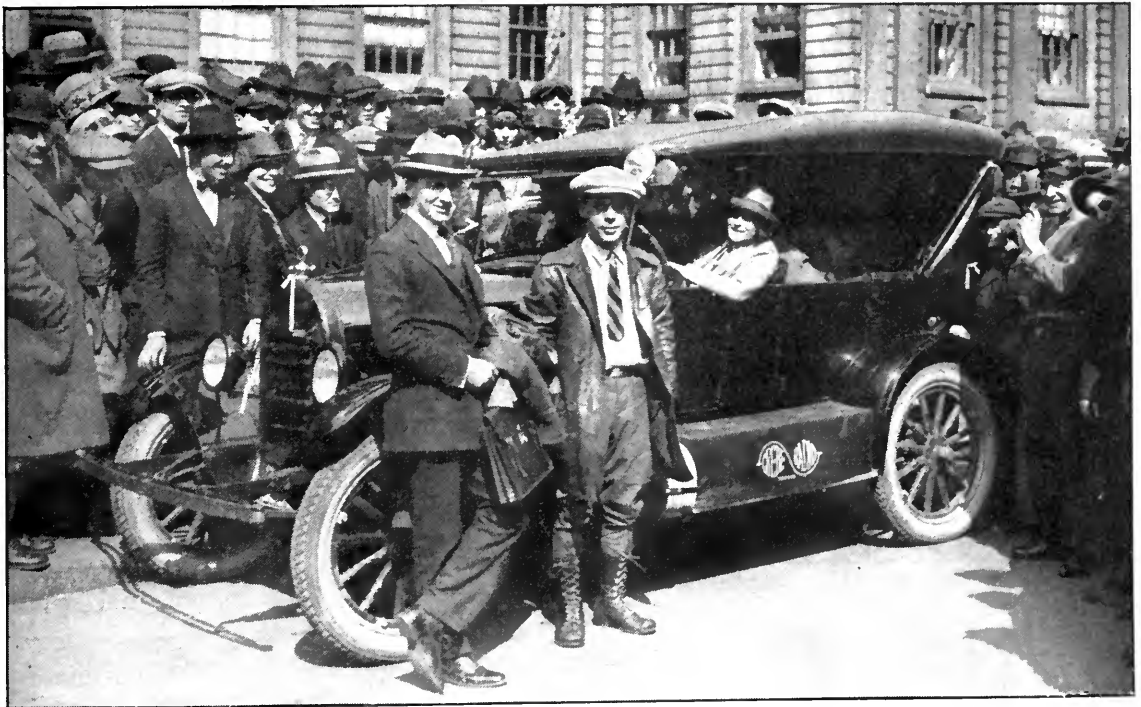

#### OFF FOR A TRIP AROUND THE WORLD

Peter Taylor, radio man (with cap); his sister, Mildred Taylor, writer (in the car); and Blanding Sloan, artist (not shown) left City Hall, New York, on April 26th for a trip to the Orient and around the world. The radio set, an important part of the travelers' equipment, was stowed on the port side of their car. Among other things, the trip will be productive of articles and photographs concerning radio in other lands, which will be prepared especially for RADIO BROADCAST. Arthur H. Lynch, (at Mr. Taylor's right), Editor of RADIO BROADCAST, joined in seeing the party off

# A Home-Made Amplifier for Any Receiver

By ZEH BOUCK

Many owners of single-tube sets who have considered adding audio-frequency amplifiers are prevented from doing so either because of the expense or because they have the idea that a two-stage amplifier is a difficult piece of apparatus to construct or handle. An inquiry into the prices of the necessary tubes, sockets, transformers, etc., will allow you to settle the cost question for yourself. This article will show that the second obstacle—difficulty of construction or operation—is somewhat of a myth. It will show you not only how to make a two-stage amplifier from standard parts, obtainable from any good radio dealer, but also how to use it to best advantage with the receiver you already have. And even if you are using or expect to use, a bought amplifier, Mr. Bouck's tips on the proper connections may put the breath of life into a "dead" set, or improve a set that is not quite "hitting on all cylinders."—THE EDITOR.

CONSIDERABLE uncertainty exists in the minds of many enthusiasts as to the operation and application of audio-frequency amplifiers, probably the most simple and most standardized of audion circuits. The impression of complication is due, for the greater part, to the general misconception that different tuning circuits require different systems of amplification. This idea is altogether at variance with fact, for the A.F. amplifier is a *unit* that can be added to *any* receiver without varying the connections to the amplifier. However, it is sometimes necessary, for greater simplicity and B battery economy, to alter slightly the plate circuit

connections of the receiver proper. The majority of unsuccessful attempts at adding audio-frequency amplification, particularly to the "Parker" circuit (Fig. 1) and the Peterson "Automatic Regenerative" circuit (Fig. 2), have been due to the failure to re-arrange the positions of the B battery and phones.

Changing the sequence, or varying the relative positions of different pieces of apparatus in a circuit, affects neither the circuit nor its operation, while it may greatly facilitate the addition of auxiliary equipment. (The fan should familiarize himself with the fundamentals of important circuits in order that he may recognize them camouflaged by the eccentricities of individual experimenters.) For example, in a single bell ringing circuit, the electrical position of the push-button is immaterial in so far as the operation of the bell is concerned. However, if more bells than one are to be operated from the solitary push-button, it must then be placed in a lead common to all bells. In a single-bulb receiving circuit, the position of the B battery is unimportant as long as it places the required positive charge on the plate and the current passes through the telephone receivers. But when amplification is added, the position of the battery must be such that it may impress its potential *across all the tubes*.

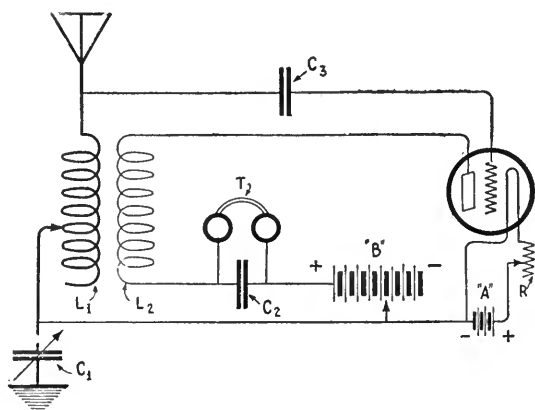

FIG. 1

Experimenters endeavoring to add amplification to this circuit have run up against many difficulties, including the burning out of tubes and the shorting of high-voltage batteries. In this case, the voltage taps are taken on the wrong side of the B battery. C<sub>1</sub> is of .001 mfd. capacity, C<sub>2</sub> is a telephone condenser of .0025 mfd. and C<sub>3</sub> is a grid condenser of .0005 mfd.

## EXAMINE THE B BATTERY CONNECTIONS

IN ARRANGING a receiver for the addition of audio-frequency amplification, it should be first determined if there are any instruments between the A and B batteries, such as telephone receivers, variometers and plate



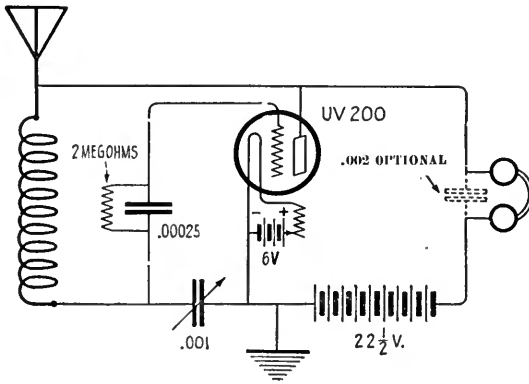

FIG. 4

This is Fig 2 corrected and ready for amplification

open-circuit type. The condenser across the input is a small fixed capacity of approximately .0015 mfd., commonly called a telephone shunt condenser. It is possible that such a condenser already exists in the enthusiast's unamplified receiver, and if such is the case, an extra capacity is not required.

The connections of the various instruments should be made with hard-drawn wire of a size not smaller than number eighteen. The wiring should be well spaced, and needless to say, every joint soldered. Particular care should be taken in making clean and firm connections to the jacks. Use the least amount of flux necessary to effect a perfect joint, and any superfluous acid or paste should be removed by wiping with a rag dipped in wood alcohol. Bungled soldering on the jacks is the cause of seventy-five per cent. of "tube noises" in audio-frequency amplifiers.

The additional B battery should be of at least 40 volts, which, when connected as indicated to the detector plate supply, will place a potential of some 60 volts on the amplifying tubes. This is generally a minimum voltage for satisfactory amplification. Still greater intensification will be had on voltages in the neighborhood of one hundred, though distortion will be more marked. The use of a power tube in the final stage of amplification will

often improve the quality of amplified speech. Voltages in excess of 100 seldom give satisfactory results on ordinary amplifiers, and should in general be avoided as it sometimes happens that this voltage results in burning out the transformer secondary.

The construction of the amplifier, while not a difficult matter, should be undertaken by the fan only after he has had the experience of building an efficient single-bulb set. The mechanical details of a popular form of construction are shown in Figs. 6 and 7, and the dimensions are approximately indicated. The panel should be of bakelite, hard rubber or a similar insulating material at least one quarter of an inch thick. The instrument shelf may be of the same material or of unpainted wood. There are several ways in which this last may be mounted, and many amateurs make the jacks do a double duty by utilizing them as supporting brackets for the shelf. This, however, subjects the panel to considerable strain, and the writer recommends the use of wooden blocks or small brass brackets. These are screwed to the panel at such a height that the tops will be on a level with the tops of the jacks (Fig. 6), which will lend an additional support to the shelf without endangering the panel. The wooden blocks should be as large as possible without being cumbersome and interfering with mounting and wiring. The small insert in Fig. 7 indicates the preferred method of mounting the sockets, transformers, etc. The cores of the transformers are placed at right angles to each other in order to reduce the possibility of inductive feed-back and

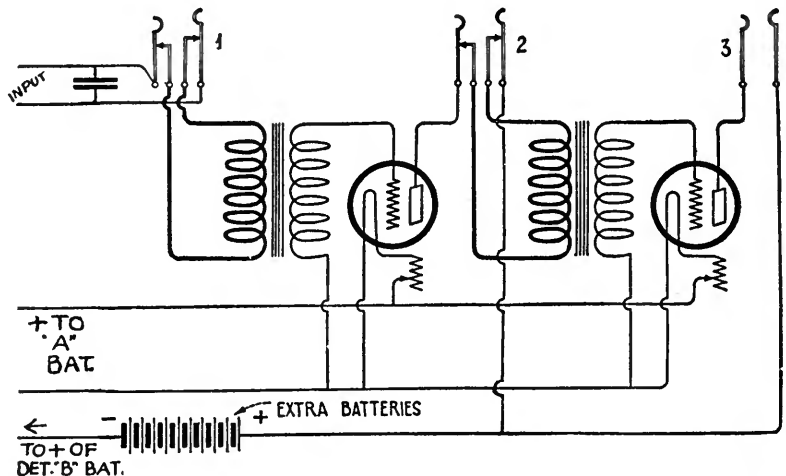

FIG. 5

The standard amplifying circuit for connection to any receiver



howling. Binding-posts on the shelf are also provided for connecting the batteries behind the cabinet.

PREPARING THE PANEL FOR DRILLING

THE panel may be drilled at an electrical or machine shop at a very small cost, and many supply houses perform this service gratis for customers who purchase from them the apparatus required in the construction of the amplifier. In preparing the panel for professional drilling, the positions of the holes should be carefully laid out and center-punched. The panel should be accompanied by a rough sketch on paper showing the locations and sizes of the holes. Excepting for the peep-holes, and those passing the rheostat shafts and jack shanks, the holes may be drilled for the passage of a No. 8 screw. This will permit the use of comfortably large wood screws, and in the case of smaller machine screws, will allow for slight inaccuracies in drilling.

If the experimenter possesses a small hand-drill, the panel work may be done on his own bench. However, he will probably find that

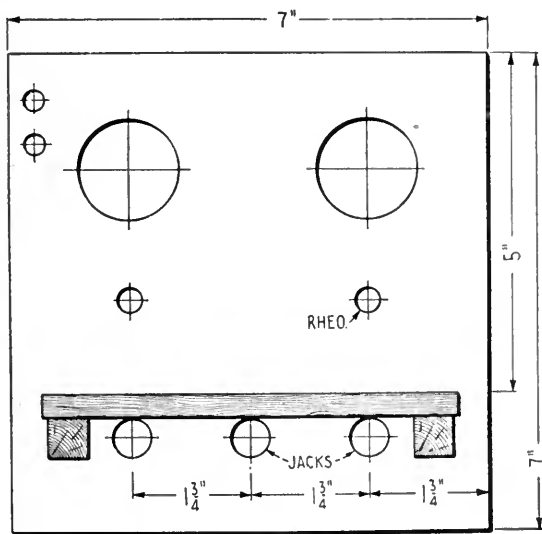

FIG. 6

Indicating the approximate dimensions of the panel and the positions of holes

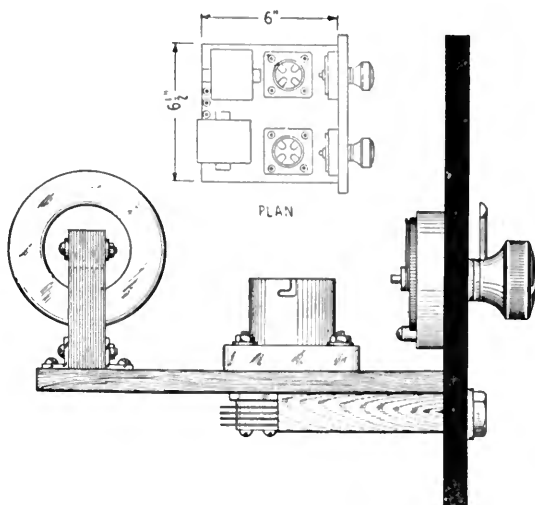

FIG. 7

Showing the preferred method of mounting the shelf and instruments behind the panel. Note the transformers at right angles to each other

the large peep-holes present somewhat of a problem. This is most easily overcome by making a group of small holes arranged symmetrically.

Before building the amplifier, the fan will do well to examine some commercial amplifier of reliable make.

The amplifier described is connected to the receiver by effecting the indicated battery connections (Fig. 5) and by connecting the input wires in place of the telephone receivers. These last should be wired to a standard plug fitting the jacks.

The experimenter need not build the two stages at one time. Even a single step adds greatly to the enjoyment one may derive from a receiving set, and it often makes possible the use of a loud speaker on near-by stations. In adding a single stage of amplification, the second transformer and tube are eliminated from Fig. 5, and the remaining connections made as indicated. A one-step amplifier will give an average signal intensification of five to twenty times, while two stages will multiply the sound of the detector output from one hundred to four hundred times.

# How Far Have You Heard?

On Any Number of Tubes

2500-mile reception has been achieved by two contestants, with home-made apparatus



Reports from all over the country indicate that our second "How Far Have You Heard?" Contest has created a great deal of enthusiasm.<sup>1</sup> Inasmuch as this issue goes to press before May 31st (the date the contest ends), it is impossible to declare the winners or to print some of the best reports; but the winners will be announced next month, and their articles, as well as others of particular interest submitted in the "How Far?" Contest, will appear in the next and subsequent issues.—THE EDITOR.

## A 5-Tube Receiver that "Delivers the Goods"

By E. D. HARRINGTON

BECOMING dissatisfied with a crystal receiving set, as most broadcast listeners do, I became more and more determined to build for myself an audion set that would satisfy the most exacting person. I began by reading available data and articles published on vacuum tubes, condensers, transformers, aerials, etc., and when more or less assured that I understood the underlying principles of radio reception, I began building my set. My observations and studies had soon assured me that although not many were as yet using radio frequency, it was by far the most desirable, in that the results obtained<sup>2</sup> seemed easily worth the increased time, effort and amount of money.

As was to be expected, I had much trouble at first and lost many good hours of sleep puzzling over different wiring diagrams, and building various sets with all sorts of hook-ups. The result was that six months after I started, I completed the set I am about to describe. In

<sup>1</sup>This Long-Distance Receiving Contest, held to determine who has done the best work with any number of tubes and any kind of receiver, was explained in full, with a list of prizes for winners, in the March, April, May, and June issues of RADIO BROADCAST.

<sup>2</sup>With the set described, Mr. Harrington has heard 16 stations more than 1000 miles from his home (Berkeley, California) including 6 more than 2000 miles away. His greatest distance is WJZ, Newark, N. J.—2550 miles.

my opinion, it is very satisfactory, quite different from the crude single-tube affair that was my first attempt. The set is selective, capable of bringing in clearly many distant stations, and has enough power to fill the whole house with music when using a Type C Baldwin phone at the end of a three-foot lacquer horn. The lacquer horn is superior to metal in that there is no metallic sound to the music heard through it. Another improvement in the quality of the music may be had by melting a very small drop of sealing wax over the pin through the center of the diaphragm of the phone. This tends to lessen any tendency of over-vibration, and will also keep the pin tight in the diaphragm.

The set is of the spider-web coil type, consisting of two stages of radio frequency, detector, and two stages of audio frequency. All controls, rheostats, condensers, coils and potentiometers are mounted on a panel of  $\frac{1}{4}$ -inch hard rubber, 9 inches high and 26 inches long, completely shielded with .002 brass. All the instruments on the panel are well insulated from the shield, and the latter grounded to the ground lead. A series-parallel switch is used in the antenna circuit to switch the aerial condenser from series to parallel for long-wave reception, and a like switch is used to cut the radio frequency in or out as desired. The latter switch is necessary for the reception of signals

of more than 600 meters, as the R. F. transformers will not handle waves over that length. Separate B batteries are used for the radio and audio frequency, but a single 6-volt A battery is used for both. Jacks for the detector and each stage of audio frequency are supplied for use on signals from stations close enough not to require the full power of the set. This saves the batteries and tubes a little.

The tuning is controlled by two condensers—a 43-plate variable in the primary circuit and a 23-plate variable and vernier in the secondary circuit—and two potentiometers, one used as a stabilizer. A word about condensers, both fixed and variable. From my experimenting with different kinds and makes of both types of condensers, I have discovered that those whose movable and stationary plates are very close to each other are not as practical as those having the plates a little farther apart because of the fact that dust particles are floating in the air at all times, and some of these settle on the plates of the condensers. In time, enough of these particles may collect so as to cause some of them to touch each other as the plates are moved, thus causing a discharge between the plates of the condenser, the dust particles acting as a high resistance conductor. If this should happen, the set would become very noisy and would cut its efficiency very materially; so, for this reason, encased condensers are best. Due to the fact that there are no spring contacts to come loose or to wear out, variable condensers whose plates are balanced have been found to be more efficient for longevity and hard use. Another important thing is the selection of fixed condensers. Paper-insulated fixed condensers are liable to puncture if high B battery voltages are being used, and when this happens it sounds as if all the arc lights and X-Ray machines in the community were inside the set! From some few experiences like the above, I have found that mica-insulated fixed condensers are more satisfactory.

The tubes are mounted in cascade, back of and about two inches away from the panel. They are placed behind their respective rheostats so as to keep the leads from the latter as

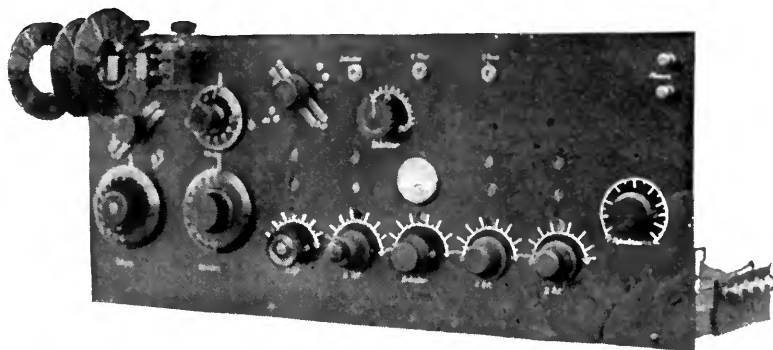

THE RECEIVER BUILT BY MR. HARRINGTON

Whose success in transcontinental reception can be attributed, in large measure, to soldered connections throughout his set

short as possible, and all the connections are soldered. Too much stress cannot be laid upon the importance of soldered connections. *All* joints and connections, leads to transformer and socket binding posts, battery binding posts, etc., should be soldered. There will be no "rock-crushers" or "stamp mills" in a set so connected. In order to keep their leads as short as possible, the transformers are set directly behind the tubes, and have their cores at right angles to each other. The transformers are separately shielded and the shields grounded. A C battery is used to impress a heavier negative charge on the grids of the amplifier tubes in the audio frequency, and this tends to cut out distortion and also to increase the volume of the signals. The voltage used here is varied to get the best results, sometimes being as low as  $1\frac{1}{2}$  volts but never over  $7\frac{1}{2}$  volts. 90 volts on the plates of the R. F. tubes, 18-23 on the detector, and 90 on the A. F. amplifiers bring the best results.

Two outside aerials are available for use. One, a 5-wire inverted L, 44 feet long and 65 feet high with a fan shaped counterpoise containing 350 feet of wire is very efficient on the more distant stations. The other, a single wire 165 feet long, 65 feet high at one end and 50 feet at the other, works very well on the local and near distant stations. The leads in are taken from the higher end and are as short as possible. For reception up to 500 miles, where great strength of signals is not desired, a loop aerial is used. With it the set becomes ultra-sensitive. Music from stations 300 miles away using a reasonable amount of power output in their aerial, comes in strong enough to operate the Baldwin phone and be heard over the entire room. Cunningham 301-A tubes are used throughout the set, and I

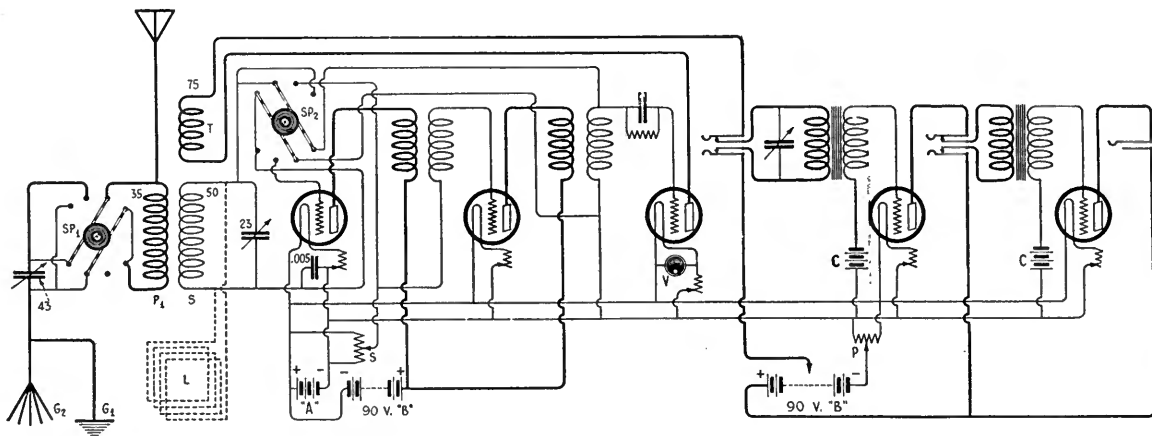

“TWO RADIO, DETECTOR, AND TWO AUDIO”

C, 7½-volt batteries for biasing A.F. tube grids; G1, earth ground; G2, capacity ground (counterpoise); V, detector tube voltmeter; SP1, series-parallel antenna condenser switch; SP2, switch for cutting R. F. in or out; S, stabilizer; P, A-battery potentiometer; L, loop which may be used instead of outside antenna when desired

have found them to give very good results. These tubes are not critical as to filament voltage, although 5 to 5½ volts on the filaments works as well as any higher voltage. These tubes “fry” less and oscillate more freely, than any other tube I have used.

Tuning the set is accomplished as follows: for wavelengths up to 375 meters, the correct size coils are placed in the coil-mountings (about 35 turns in the primary, 50 in the secondary, and 75 in the tickler). The bulbs are turned to their right temperatures and the aerial condenser is switched to series with the aerial, and the R. F. switched in. The primary condenser is then turned to somewhere between 0 and 40 on the dial (usually about 25), and the secondary condenser is slowly rotated from 0 to maximum until a shrill whistle is heard. The stabilizer is then adjusted until voice or music is distinct and clear. Usually the secondary condenser, vernier and stabilizer must be re-adjusted slightly, and then the concert or address “picked up” may be enjoyed to the greatest extent. Moving the coils and changing the stabilizer and vernier will enable a

person to hear different stations operating on nearly the same wavelength. If the primary condenser be turned farther toward maximum and a larger coil inserted in the primary circuit, stations of different wavelength may be brought in. For 400-meter stations I have found that 50 turns in the primary and secondary, with 100 turns in the tickler give the best results, the signals being clear and loud, with a minimum of interference from 360-meter stations and amateur stations. Flat-wound pancake coils seem to give quite the best results.

In the short space of the half-hour in the evening while local broadcasters are quiet, I have been able to tune in as many as 18 different stations. Those within 500 miles may usually be brought in while local broadcasters are in the air, with no interference from the latter. This is especially true when using a loop aerial. The loop used with this set is two feet square and has twelve turns of wire.

In conclusion, I will say, that for one who wishes a set that is sensitive, selective, powerful and easy to operate, this set gives great satisfaction.

## REPORTS FROM OTHER ENTRANTS IN THE “HOW FAR?” CONTEST

FINE WORK FROM A REMOTE CORNER OF THE U.S.

**M**R. LESTER WITHERBY, who lives in Ferndale, Washington—a hundred miles north of Seattle, near the Canadian border, has done some remarkable receiving with a 3-circuit two-bulb set, for which he wound his own

multi-layer coils. His list of stations is too long to publish here, but his three greatest jumps are WGY, Schenectady, N. Y., 2,500 miles; NOF, Anacostia, D. C., 2,475; and KGU, Honolulu, 2,300.

Mr. Witherby has supplied the following “dope,” which, with the photo and circuit

diagram shown, should enable the experienced radio fan to build a similar set (the 3 coils and coil mounting may, of course, be bought if desired):

"My set is a home-made one and consists of a detector and one stage of audio-frequency. It is mounted on a bakelite panel 6½ inches by 15 inches.

"I use three honeycomb coils of 35, 50 and 75 turns each, in the primary, secondary and tickler respectively, with a 43-plate vernier condenser across the secondary coil.

"The only thing to bother about my set was to get it to oscillate on 400 meters without an extra amount of current on the detector. To overcome this trouble, I placed a .001 mfd. fixed condenser across the primary of my amplifying transformer which helped considerably in cutting down the filament current.

"I made my own honeycombs and also the mounting, which is similar to a Remler mounting except that the contact is made with spring brass clips instead of brass plugs.

"In tuning, I set the coils near the wave with the condenser clearly with the vernier condenser

rheostat. One thing that gives me volume and very little noise is the use of a 1) transformer.

"My aerial, about 30 feet long including lead-in, is made of the copper ribbon from a field coil of a Ford magneto. It works fine because of its extra surface.

"The set is wired with 14 copper wire, and all joints are soldered.

"All measurements for range were taken on a Randall & Co. copyrighted map. This map checked closely with Cram's official radio range map.

"Being located in the northwest corner of the United States and therefore unable to get any stations north or west, I consider my aggregate range better than the same range at some central point. Some stations, such as Atlanta, Birmingham, New Orleans, etc., are as far from Ferndale as they are from any place in the United States

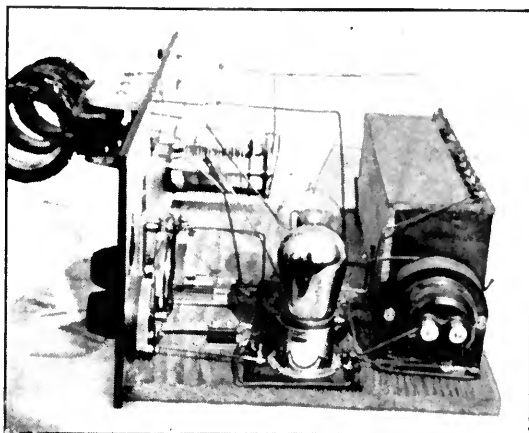

MR. WITHERBY'S SET IS SIMPLE  
But it has reached out 2500 miles

YOUNGSTER AMONG THE LEADERS

ROSCOE ROBINSON of Ponca City, Okla-



AMERICAN TELEPHONE AND TELEGRAPH COMPANY, NEW YORK  
commanding a view of both studios, the announcer can "cut in" an  
while an orchestra, for example, is preparing to "go on" in this one



RECEPTION ROOM, WITH DOORS LEADING TO BOTH STUDIOS

B. C., and WGAD, Ensenada, P. R. He has included no stations within 150 miles of his receiving station, and Ensenada is his best single jump—approximately 2,000 miles.

Henry Duderstadt of Kansas City, Mo. has heard 110 stations from 150 to 1,550 miles from his home, and his aggregate mileage is 69,980. Mr. Duderstadt is using a Grebe CR-9. He has listed but 7 stations less than 200 miles distant; 13, between 200 and 300 miles; 7 between 300 and 400; 20 up to 500; 15 up to 600; 10 up to 700; 8 up to 800; 5 up to 900; 2 up to 1,000; 3 to 1,100; 5 to 1,200; 1 to 1,300; 4 to 1,400; 3 to 1,500, and 4 up to 1,600. His list would make a pretty good broadcasting directory in itself and it has been sworn to before a notary.

Curtis Herbert of Rutherford, N. J. has heard 88 stations from 180 to 3,200 miles distant with an aggregate mileage of 69,501 on a home-made single-circuit regenerative. These tubes are not critical as to maximum filament voltage, although 5 to 5½ volts on the filaments works as well as any higher voltage. These tubes "fry" less and oscillate more freely, than any other tube I have used.

Tuning the set is accomplished as follows: for wavelengths up to 375 meters, the correct size coils are placed in the coil-mountings (about 35 turns in the primary, 50 in the secondary, and 75 in the tickler). The bulbs are turned to their right temperatures and the aerial condenser is switched to series with the aerial, and the R. F. switched in. The primary condenser is then turned to somewhere between 0 and 40 on the dial (usually about 25), and the secondary condenser is slowly rotated from 0 to maximum until a shrill whistle is heard. The stabilizer is then adjusted until voice or music is distinct and clear. Usually the secondary condenser, vernier and stabilizer must be re-adjusted slightly, and then the concert or address "picked up" may be enjoyed to the greatest extent. Moving the coils and changing the stabilizer and vernier will enable a

Among the contestants who are below 50,000 is Daniel Lamb of Mesa, Ariz., who uses a home-made single-circuit regenerative outfit and has heard 39 stations from 200 to 2,300 miles distant. His aggregate is 36,950. He mentions, however, that this list is not complete and that he has only recorded some of the best distance work he has done. Perhaps the present list may be considerably increased if all his stations are included.

Alex H. McKay, of Bradford, Pa., using a single-circuit regenerative receiver and two stages of audio-frequency amplification, has heard 72 stations 150 to 1,450 miles distant and his aggregate is 36,710. His 1,450 mile hop is to San Antonio, Texas.

A. J. Wishart and L. D. Thorpe of Perdue, Saskatchewan have sent in a joint report of 34 stations from 150 to 2,700 miles, with an aggregate mileage of 30,925. They use a standard three-circuit regenerative receiver.

condenser of 1 B. Horne of Montreal, Quebec, and a larger coil Sr. has heard 47 stations from 150 to 2,700 miles, with an aggregate mileage of 30,925. They use a standard three-circuit regenerative receiver.

condenser of 1 B. Horne of Montreal, Quebec, and a larger coil Sr. has heard 47 stations from 150 to 2,700 miles, with an aggregate mileage of 30,925. They use a standard three-circuit regenerative receiver.

condenser of 1 B. Horne of Montreal, Quebec, and a larger coil Sr. has heard 47 stations from 150 to 2,700 miles, with an aggregate mileage of 30,925. They use a standard three-circuit regenerative receiver.

condenser of 1 B. Horne of Montreal, Quebec, and a larger coil Sr. has heard 47 stations from 150 to 2,700 miles, with an aggregate mileage of 30,925. They use a standard three-circuit regenerative receiver.

condenser of 1 B. Horne of Montreal, Quebec, and a larger coil Sr. has heard 47 stations from 150 to 2,700 miles, with an aggregate mileage of 30,925. They use a standard three-circuit regenerative receiver.

condenser of 1 B. Horne of Montreal, Quebec, and a larger coil Sr. has heard 47 stations from 150 to 2,700 miles, with an aggregate mileage of 30,925. They use a standard three-circuit regenerative receiver.

condenser of 1 B. Horne of Montreal, Quebec, and a larger coil Sr. has heard 47 stations from 150 to 2,700 miles, with an aggregate mileage of 30,925. They use a standard three-circuit regenerative receiver.

condenser of 1 B. Horne of Montreal, Quebec, and a larger coil Sr. has heard 47 stations from 150 to 2,700 miles, with an aggregate mileage of 30,925. They use a standard three-circuit regenerative receiver.

condenser of 1 B. Horne of Montreal, Quebec, and a larger coil Sr. has heard 47 stations from 150 to 2,700 miles, with an aggregate mileage of 30,925. They use a standard three-circuit regenerative receiver.

condenser of 1 B. Horne of Montreal, Quebec, and a larger coil Sr. has heard 47 stations from 150 to 2,700 miles, with an aggregate mileage of 30,925. They use a standard three-circuit regenerative receiver.

## REPORTS FROM OTHER ENTRANTS IN THE "HOVOR"

### FINE WORK FROM A REMOTE CORNER OF THE U.S.

MR. LESTER WITHERBY, who lives in Ferndale, Washington—a hundred miles north of Seattle, near the Canadian border, has done some remarkable receiving with a 3-circuit two-bulb set, for which he wound his own

multi-layer coils. He has heard 35 stations from 150 to 1,950 miles distant. His aggregate mileage is 19,210. He uses a spider-web regenerative outfit that he built himself. He has heard 35 stations from 150 to 1,950 miles distant. The 1,950 mile jump is to KDKL, Salt Lake City, Utah and his aggregate mileage is 19,210.

# WEAF's New Home



THE LARGE STUDIO OF THE AMERICAN TELEPHONE AND TELEGRAPH COMPANY, NEW YORK

From a control booth commanding a view of both studios, the announcer can "cut in" an artist in the small room, while an orchestra, for example, is preparing to "go on" in this one



THE COMFORTABLE RECEPTION ROOM, WITH DOORS LEADING TO BOTH STUDIOS

# All Boy Scouts, Attention!

RADIO BROADCAST announces a contest, ending July 31, 1923, to determine WHAT BOY SCOUT TROOP HAS DONE OR IS DOING THE MOST WITH RADIO.

## Prizes for Winning Articles

FIRST PRIZE: CROSLY MODEL X 4-TUBE RECEIVER.

This receiver, which may be used with dry-cell tubes if desired, consists of detector, one stage of tuned radio-frequency and two stages of audio-frequency amplification. (Advertised in RADIO BROADCAST).

SECOND PRIZE: MUSIC MASTER LOUD SPEAKER.

This is the new loud speaker made by the General Radio Corporation. (A picture and description of it appear in the advertising pages of RADIO BROADCAST).

THIRD PRIZE: THREE

The WD-11 is the well-known dry-corporation. (Filament voltage 1.5, of the third prize may have UV-190's

A YEAR'S SUBSCRIPTION TO given as prizes for the ten next best

These prizes will be awarded to troop may delegate one of its members to



WD-11 VACUUM TUBES.

cell tube manufactured for the Radio plate voltage 22½—45). The winner or UV-201-A's if he prefers.

"RADIO BROADCAST" will be contributions in this contest.

troops, not to individuals, although any prepare the story.

## Rules of the Contest

1. Articles must be true accounts of radio with relation to your particular troop: what you have done, or are doing, or both.
2. Every article must be written by a Scout or by more than one Scout belonging to one troop.
3. Articles should be between 500 and 1000 words long.
4. Good photographs to illustrate the article will count 50% in judging contributions.
5. Typewritten manuscript, double-spaced, is desired, though not required.
6. Address contributions to Scout Contest, Radio Broadcast, Doubleday, Page & Company, Garden City, N. Y.

Scouts have done splendid work in maintaining communication by radio in time of floods and disaster, in copying and spreading the market reports transmitted by the government Farm Bureaus, in training themselves along mechanical and electrical lines, and, in short, in using radio as a part of scout work in a way consistent with the best traditions of scouting. What have you to tell of your troop's past or present activities? Get your scribes and photographers under way with that story which will put in a strong bid for first prize. How would a receiver with three stages of amplification go in your troop?

Beginning with the August number of RADIO BROADCAST, the best articles will be published. The winners will be announced in the September number, and unless the three best articles have been previously published, they will appear in that issue.



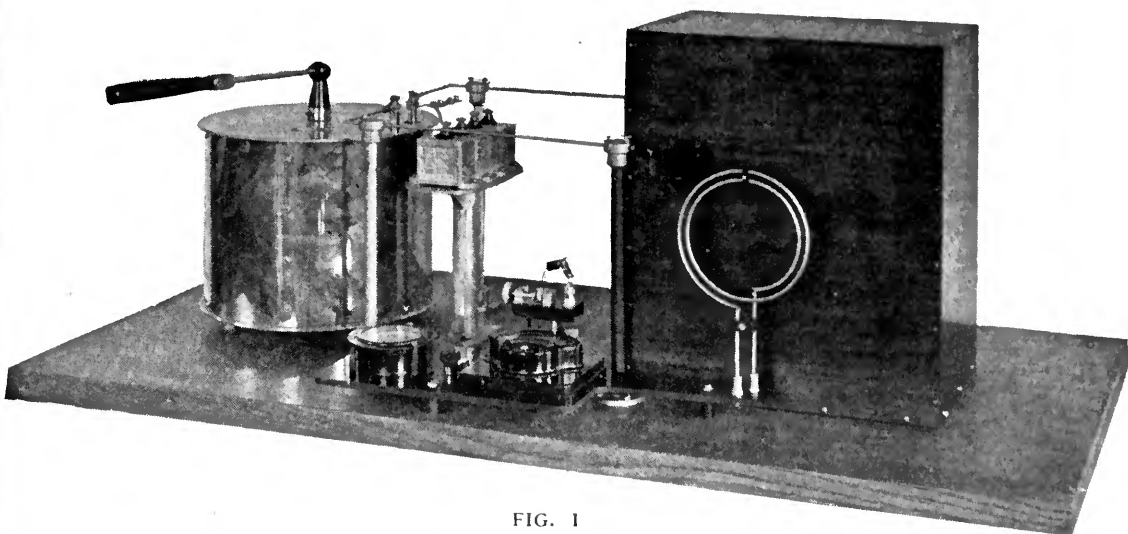

FIG. 1  
Standard wavemeter of the Bureau of Standards

## Reducing the Guesswork in Tuning<sup>1</sup>

How the Bureau of Standards Will Measure the Wavelengths of Broadcasting Stations with an Accuracy of 99.9%, Making it Possible for Any One to Use His Receiving Set as a Wavemeter

By J. H. DELLINGER

Chief, Radio Laboratory, Bureau of Standards

THE good results already appearing from the recommendations of the Second National Radio Conference could easily be wrecked if the radio broadcasting stations and other stations should not operate accurately on the frequencies to which they are assigned. One of the reasons why interference has been the great draw-back to progress in radio has been that the transmitting stations have used waves which approximated the assigned wavelength or frequency only very roughly indeed. Among its numerous tasks of standardization and research, the Bureau of Standards has devoted itself with some vigor to the task of improving the frequency standards of the country, with the result that there is every prospect that the interference situation will be greatly relieved from now on. The Bureau's work in this direction<sup>2</sup> has been directed at two objectives:

<sup>1</sup>Published by permission of the Director, Bureau of Standards.

<sup>2</sup>Among those who are engaged in this important work, under Dr. Dellinger's direction, are Mr. E. L. Hall, the Misses F. Kenyon and G. Hazen, Mr. F. W. Dunmore, Mr. F. H. Engel, and Mr. H. J. Walls.

increasing the accuracy of its standards, and making these standards available to the radio public.

About a year ago the Bureau began a program of work which would materially improve the accuracy of its radio-frequency measurement. Prior to that time the basic wavemeter standards were based entirely on circuits made up of standard capacities and inductances, the values of which were either calculated or measured at low frequencies. These standards were prepared with great care and precautions were taken to avoid errors in the measurements, but there was no certainty that the frequency basis thus established could be relied upon to be correct within less than 1 per cent., particularly for the very high radio frequencies. The work that has been done recently has given a new basis of measurement, resulting from several interesting and quite independent methods of frequency determination, and is much more accurate. The goal set in this work was an accuracy of 99.9 per cent. The reason why this degree of accuracy is important may be seen from a brief consideration of the

frequency assignments to broadcasting stations. The waves used by the broadcasting stations are spaced 10 kilocycles apart (3 meters at a wavelength of 300 meters). Thus one station is on 990 kilocycles, another on 1000, and another on 1,010 kilocycles. If one of these is inaccurately adjusted by as much as 0.1 per cent, this would mean a variation of 1 kilocycle from the established value. The next station having a frequency only 10 kilocycles different, this variation of 1 kilocycle is decidedly appreciable in comparison with the 10 kilocycle separation. A variation of the frequency of 1 per cent, for example, would be a variation of 10 kilocycles and could cause one station to be using exactly the wave that had been assigned to another. The whole success of American broadcasting is thus tied up with the placing of broadcasting stations on the correct frequencies to an accuracy approaching 99.9 per cent. Since receiving sets are now available by which an individual can hear the stations from all over the United States on the same night, the importance of this accuracy is apparent.

The basis of frequency measurement of the Bureau of Standards includes absolute frequency measurements by four entirely independent methods. These are:

A. Measurement or calculation of capacity

and inductance of carefully constructed standard condensers and inductors.

B. Measurement of frequency of the sound from a tuning fork, together with measurement of ratio of such frequency to radio frequencies by use of harmonics from an electron tube generator.

C. Measurement of frequency of the sound of a tuning fork, together with measurement of the ratio of such frequency to radio frequencies by the use of Lissajous figures produced by the direct application of the two frequencies to a cathode-ray oscillograph. This method is free from the assumption of integral ratios involved in the harmonic method (B).

D. Measurement of the actual length of very short waves and calculation of the frequency from this and the known velocity by the relation,  $f = v/\lambda$ . ( $\lambda$  = wavelength in meters). Ratios of frequencies thus measured, to lower radio frequencies, are obtained by the same general methods for ratio measurements as in B and C.

These four methods are not all that are theoretically possible. Another one that could be used is the accurate measurement of the speed of a radio-frequency alternator. Every method goes back ultimately to the measurement of a time interval.

Method A was the first method to be used by the Bureau of Standards. Where this system is employed, the capacity of specially designed condensers are measured by their charge and discharge at about 1 kilocycle. The inductance of the standard inductors is measured at the same frequency. The design of both capacity and inductance standards is such that there is no appreciable change with frequency. The capacity of coil and leads is measured by the use of harmonics as described on page 100 of the Bureau of Standards Circular 74, entitled "Radio Instruments and Measurements." This standard wavemeter, with its instruments for indicating resonance, is shown in Fig. 1.<sup>1</sup>

Method B employs the frequency of a tuning fork as the starting point, measuring the ratio of such frequency to radio frequencies by means of harmonics of the current in an electron tube generator. The use of harmonics for establish-

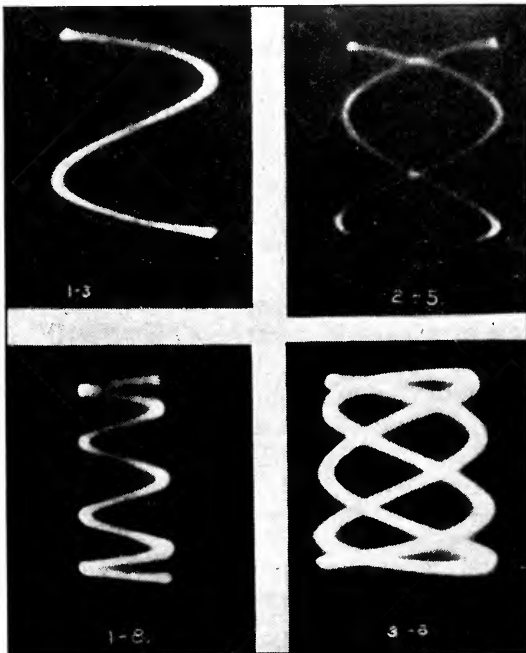

FIG. 2

Lissajous figures giving accurate frequency ratios

<sup>1</sup>Further information on the standard wavemeter is given in an article now in preparation entitled, "The Standards of Radio Frequency of the Bureau of Standards," by Mr. E. L. Hall, who is in charge of radio standards and testing. The time and place of publication of that article, and others referred to below, will be announced in the Radio Service Bulletin.

ing radio frequency ratios has been described in Circular 74, page 103. The method has been especially developed by Prof. H. Abraham whose apparatus is known as the multivibrator. The multivibrator has not been set up in the Bureau of Standards laboratory, but has been in use in the Naval Radio Research Laboratory located at the Bureau of Standards. Comparisons of this multivibrator and the other methods have been carefully made throughout the range from 18 to 3600 kilocycles.

In method C, the frequency of a tuning fork is carefully measured with a chronograph, and ratios of this to frequencies in the radio range are measured by the use of the cathode-ray oscillograph. This device is a special kind of vacuum tube in which a beam of cathode rays produces a spot of light on a fluorescent screen placed in the end of the tube. When the beam is deflected the spot moves across the fluorescent screen. Provision is made for deflecting the beam in two directions at right angles to each other by two pairs of small condenser plates to which controlled voltages may be applied. When two alternating voltages are applied which have frequencies related by a simple ratio, the spot of light traces out a Lissajous figure on the fluorescent screen. The shape of the Lissajous figure tells the ratio; the examples in Fig. 2 show this. The two pairs of deflecting plates are connected in parallel with the condensers of two independent generators of currents of audio or radio frequency. In the first step of the standardization process, the "low-frequency" generator, Fig. 3, is an electron tube generator of approximately 1 kilocycle, the frequency of which is determined by the tuning fork. The "high-frequency" generator is an electron-tube generator having a frequency anywhere from  $1\frac{1}{2}$  to 22 times this, the frequency being varied until successive Lissajous figures appear on the screen. The frequency ratio thus measured is extremely accurate, being in all cases closer than the accuracy of setting of the standard wavemeter, which is tuned to the frequency of the "high-frequency" generator. The method was largely developed by Mr. R. T. Cox. Its use will be described in a separate publication entitled, "Primary Radio Frequency Standardization by Use of the Cathode-Ray Oscillograph," by Misses F. Kenyon and G. Hazen.

In method D, a direct measurement of the wavelength of short waves on wires is made by coupling a short-wave generating set (Fig. 4) to

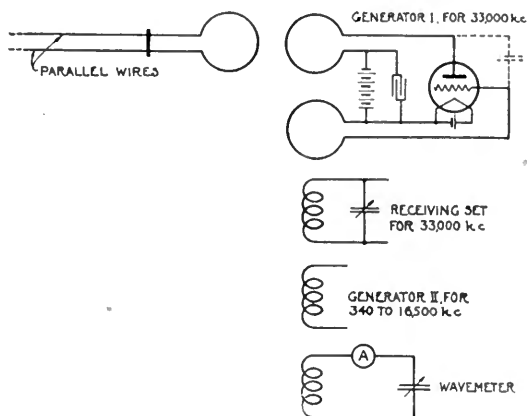

FIG. 3

Showing connections of generators whose frequencies are compared by the cathode-ray oscillograph

a loop of wire connected to one end of two long parallel wires approximately 4 centimeters apart. A short wire at right angles to the parallel wires, and containing a thermo-element is moved along the parallel wires and the positions of successive maxima of current are noted. The distances between these positions are each a half wavelength. They are measured with a steel tape, and agree within a few hundredths of one per cent, for the wavelengths used, 9 and 16 meters. These wavelengths correspond to frequencies of approximately 33,000 and 19,000 kilocycles respectively. These frequencies are not so high as to be beyond practical application in radio telegraphy and telephony. Experiments at the Bureau have shown how to produce them and to use them for communication as well as for measurements.

The method of harmonics has been used to step down from the very high frequencies thus produced and measured to radio frequencies in the whole range down to 340 kilocycles. This is done by placing between generators I and II (Fig. 5) a receiving set tuned to the frequency of generator I which produces the current in the parallel wires. Generator II is an auxiliary, the frequency of which is varied until one of its harmonics approaches the frequency of generator I. The frequency of Generator II is adjusted until the beat note heard in the receiving set becomes zero. The wavemeter is meanwhile tuned to the frequency of the generator II. The frequency for that setting of the wavemeter is then the frequency obtained from the wavelength measured on the parallel wires, divided by the number of the

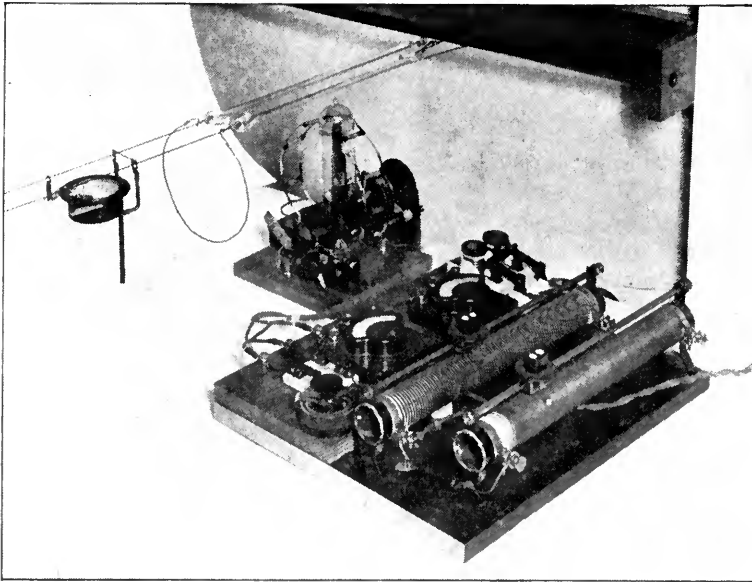

FIG. 4

Generator, detecting instrument, and end of parallel wires used to measure very high frequencies

harmonic. The measurement of these very high frequencies and establishment of the frequency basis by this method is described in a paper prepared by Messrs. F. W. Dunmore and F. H. Engel entitled, "A Method of Measuring Very Short Wave Lengths and Their Use in Frequency Standardization."

The step down from the very high frequencies to some of the more commonly used radio frequencies can also be made by the cathode-ray oscillograph, as described above, obtaining a Lissajous figure directly between the very high frequency and a lower one from an auxiliary generator, the latter frequency being measured by the wavemeter. The method is difficult at such high frequencies, and the work is still in progress.

The results of the independent establishment of the frequency basis by methods A, B, C, and D have been intercompared and the order of agreement is 0.1 per cent. to 0.2 per cent. When the present series of measurements is completed, the Bureau of Standards frequency basis will be certainly accurate well within 0.1 per cent. This frequency basis extends from 3.5 to 33,000 kilocycles.

While an accuracy of 0.1 per cent. is all that has been sought, for present needs, this will clearly not be adequate for the future. It is highly desirable for some purposes to place a heterodyne receiving set on a definite pre-

determined frequency with great accuracy. It would be possible to recognize transmitting stations by the beat note produced in such a heterodyne receiving set. This is important for certain Navy requirements. In order that the beat note may not vary from the pre-determined value by more than, say 100 per second, this means that the station which it is desired to receive should have its frequency adjusted accurately to  $\frac{1}{100}$  of a kilocycle which is 0.01 per cent. for a frequency of 1,000 kilocycles. It will be quite possible in the next year or two to attain this accuracy (0.01 per cent.) through further series of careful measurements and particularly by improvements in

the frequency standards and methods of indicating resonance.

The frequency standards have in past years been made available to the country only through the standardization of wavemeters at the Bureau of Standards. This service is now extended through the transmission of standard frequency signals and through measurements at the Bureau of the frequency of various transmitting stations. Only a small amount of direct wavemeter standardization can be done by the Bureau. Because of the Bureau's limited personnel, it has been necessary to restrict tests of wavemeters and other apparatus solely to important standards. The transmission of signals of standard frequency, however, which was begun in March of this year, places the frequency standards in the hands of all who care to use them. These signals are sent out approximately monthly, with special repetitions weekly during May and June, 1923. Starting at 11 P. M., so as not to disturb broadcast programs, some eight or ten standard frequencies are transmitted, the intervals between transmissions on the particular frequencies being approximately 15 minutes. Announcements are given both in radio telephony and in continuous-wave telegraphy, and the standard frequency is transmitted as a series of long dashes and the letters WWV. Methods by which these waves can be received

and wavemeters standardized are very simple. Information on this matter is given in Bureau of Standards Letter Circular No. 92, a limited supply of which is available at the Bureau of Standards, Washington, D. C. The standard frequency signals are transmitted with an electron tube set rated at 1 KW, having a radiation of approximately 150 meter-amperes. The schedules of transmission are announced in the newspapers and in the Radio Service Bulletin. The transmission and utilization of the standard frequency signals are further described by an article in preparation by Mr. H. J. Walls, entitled, "Radio Signals of Standard Frequency."

These signals are received and used throughout the United States east of the Mississippi River. No permanent means have as yet been provided for extending this range to cover the western part of the United States. One method that may be used is the transmission of signals, the frequency of which is kept constant for a certain number of minutes, by a Mid-Western broadcasting station. Measurements of this transmission can then be made by any one, using the same methods as are used for receiving the Bureau of Standards signals of standard frequency. The measurements will simultaneously be made by the Bureau of Standards and the values so measured will be announced by the Bureau.

A final method of supplying frequency standards uses the ether itself as a wavemeter. The transmitting stations operating on definite frequencies are the points on this wavemeter. Broadcasting and other stations will more and more from now on utilize a radio frequency indicator to assure operation on the assigned frequency every time they transmit. Measurements of the actual transmitted frequencies of various stations are made from time to time at the Bureau of Standards. When these measurements for a given station show great

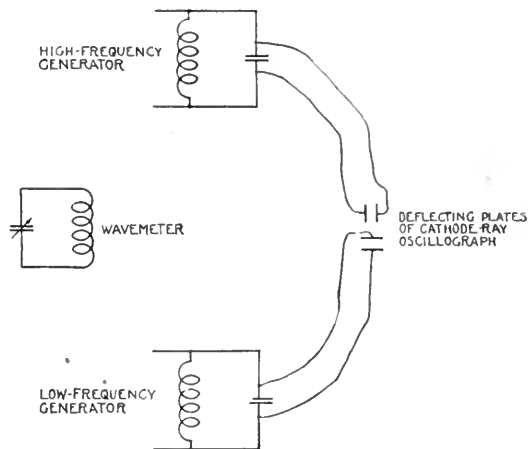

FIG. 5

Arrangement of apparatus for stepping down from very high frequencies

constancy, and the station is known to use a suitable frequency indicator, so that the Bureau is convinced that the station's operating wave can be used as a frequency standard, the Bureau will so announce. These announcements will probably be made in the Radio Service Bulletin. The transmissions from such stations can then be used as known points on the ether wavemeter.

Summarizing, means have been provided whereby accurate frequency adjustment of radio stations is possible. Great improvements have been made in the primary frequency standards and in their availability to the public. This will of itself remove a large portion of existing radio interference and make it possible to realize the benefits of the new frequency allocations recommended by the Second National Radio Conference. It seems quite certain that before long the ether itself will be a standard wavemeter with the frequencies of a number of the transmitting stations as its fixed points.

## Next Month! The Ultimate Receiver

Mr. Walter Van B. Roberts, whose articles "A Single-Tube Loop Set in a Brief Case" and "Operating a Loud Speaker on One Tube, Without Batteries" appeared in our May and June issues, respectively, is preparing another article—just as interesting and even more important—for our August number. In building the particular kind of super-heterodyne receiver which he is going to describe, Mr. Roberts has incorporated suggestions from the best technicians of to-day. Although having but two wavelength controls, this receiver is to combine the best there is in the super-heterodyne, the neutrodyne and inverse-duplex methods. With a laboratory model, Mr. Roberts is hearing KFI and KHJ (from Princeton, N. J.) on a loop and five tubes. We know of no receiver that exists which will compare in selectivity, long range and ease of operation with the one which Mr. Roberts will describe in RADIO BROADCAST for August.—THE EDITOR.

# Recent Broadcasters in New York Studios



**S. L. ROTHAPFEL FILLING THE AIR WITH FUN**  
 He receives, on an average, 1500 letters a week from listeners-in who enjoy his witty announcements between selections broadcasted from WEAF via the Capitol Theatre, of which he is the Director



© Underwood & Underwood  
**FRIEDA HEMPEL SINGS "HOME SWEET HOME"**  
 As part of the celebration of the 100th anniversary of John Howard Payne, creator of the best-known song in the world. In the picture Miss Hempel is shown at WJZ's Waldorf Astoria studio

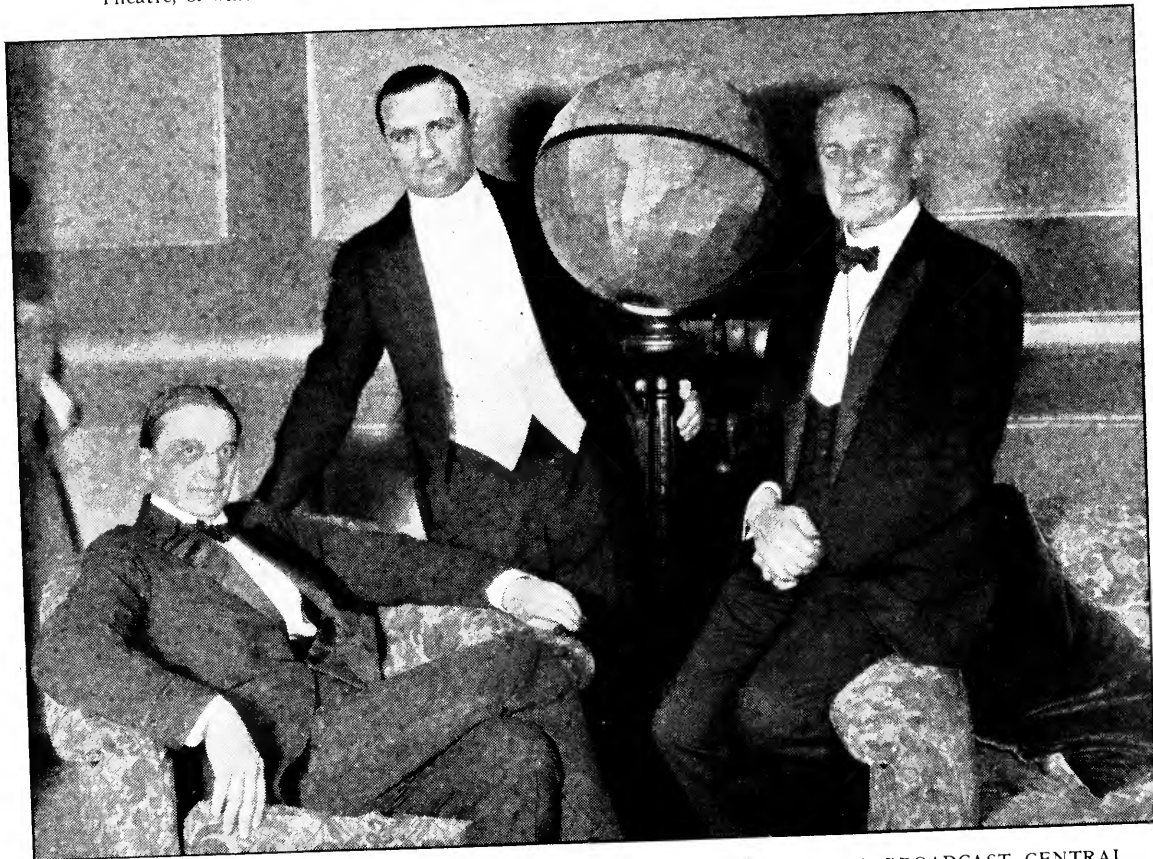

**THREE RADIO CORPORATION PRINCIPALS AT THE OPENING OF RADIO BROADCAST CENTRAL**  
 Left to right: Mr. Owen D. Young, Chairman of the Board of Directors; Dr. Alfred N. Goldsmith, Director of Research, and Major-General James G. Harbord, President of the Radio Corporation of America. Their speeches marked the opening of the Aeolian Hall stations, WJZ and WJY, on May 14th

# Dry Cells and UV-199's

By E. E. HORINE

National Carbon Company, Inc.

THE UV-199 vacuum tube is the latest and smallest member of the Radiotron family. The men responsible for its development, realizing the handicaps of the storage battery for radio receiving, have made it a dry cell tube. And while the voltage required to operate this tube is higher than for other dry-cell tubes, it is so sparing of current that under certain circumstances it is entirely feasible to operate it from an A battery made up of flashlight cells!

This remarkable decrease in filament energy, compared with storage battery tubes, has not been accomplished at a sacrifice of other desirable features. As a matter of fact, the electron emission from the tiny UV-199 filament is greater than from the husky filament used in the UV-201, which requires 1 ampere at 5 volts for normal operation. This gives the UV-199 somewhat better characteristics as an amplifier, because with greater electron emission, larger B battery energy is made available for the operation of the telephone receivers.

Prior to the introduction of the UV-199, about the only dry-cell vacuum tube available to the public was the WD-11. This was really the first tube put out which gave successful results on dry cells. The phenomenal popularity of the WD-11 is due to its ability to use dry cells, with advantages of low cost, reliability,

freedom from attention, and ease of renewal. It is not surprising, therefore, that the WD-11 should prove to be the forerunner of the dry-cell class of tubes.

The filament of the UV-199 differs somewhat from that of the WD-11 in its electrical characteristics, in that the UV-199 is what we might call a high-voltage, low-current tube, while the WD-11 is a low-voltage, high-current tube. Although both tubes were designed to utilize the energy of dry cells, this outstanding difference in filament characteristics makes it necessary to employ different battery connections for the two tubes.

The current required by the UV-199 tube is .060 ampere (60 milliamperes). The voltage necessary to force this current through the filament is 3.0 volts, and in order to get this voltage, three dry cells connected in series must be employed. Herein lies what to some is considered a discrepancy. It is generally known that the voltage of an unused dry cell is 1.5 volts. Actually, it is usually

in excess of this figure, sometimes running as high as 1.6 volts in new cells, but for convenience, and to employ round numbers, it is usually stated as being 1.5 volts. Since the UV-199 requires only 3.0 volts, the question naturally arises, "Why is it necessary to use three dry cells? Why not two?"

It must be remembered that one of the char-

## Do You Know

Why it is more economical to use three dry cells rather than two, to operate a UV-199 tube, although the rated filament voltage of the tube is 3, and three dry cells in series deliver  $4\frac{1}{2}$  volts?

Why it is more economical to use three dry cells than four, even though four permit each cell to be used for a longer period?

Why, with 199's, it is best to use large B batteries, except for portable sets, in which lightness comes first in importance and operating cost comes second?

What the "cut off" voltage of dry cells is, and how it governs your operating expense?

Why it is more economical to use large dry cells than those of the flashlight variety for your A battery, although the voltage rating of each is the same?

Why, when operating one, two, or three 199's from three cells, you should use a 30-, 20-, or 10-ohm rheostat respectively?

These facts and others are thoroughly and interestingly described in this article. In presenting this work of Mr. Horine's to you, RADIO BROADCAST believes it is performing a valuable service. This is the type of article you will want to read at once, to be thoroughly posted on the UV-199 tube; and you will do well to keep it handy for future reference.—  
THE EDITOR.

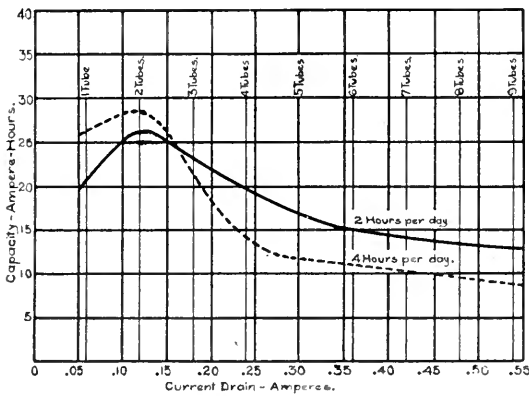

FIG. 1

Illustrating how different current drains affect the capacity of a dry cell

acteristics of dry cells is that the voltage drops slightly when current is drawn from them. The nominal figure of 1.5 volts per cell is what is known as the "open circuit voltage"; that is, the voltage of the cell when delivering no current. As soon as the cell is connected to any device which draws current from it, a different voltage, called the "closed circuit voltage" is obtained. The closed circuit voltage of a dry cell is always less than the open circuit voltage.

Obviously, it is the closed circuit voltage of the cell that we are primarily interested in. And while a battery made up of two dry cells connected in series will have an open circuit voltage of 3 volts, the minute such a battery begins delivering current to one or more UV-199 tubes the voltage will drop to something under 3 volts, which is less than that required by the tube for satisfactory operation.

Another important reason for using a battery of three cells connected in series for UV-199 tubes lies in the matter of service obtainable from the cells. As more and more energy is drained day after day from them, the voltage gradually drops, until eventually the available closed circuit voltage is just equal to that required by the tube. Any further withdrawal of energy will reduce the cell voltage to a point lower than that required by the tube, and unsatisfactory operation will result. It is evident that the lower this permissible minimum voltage (called the "cut-off voltage"), the more energy may be obtained from the cells. The cut-off voltage is determined by the electrical characteristics of the filament, which, in the case of the UV-199, is 3.0 volts.

Therefore, when three cells are used, the range through which they can be worked is the

difference between the initial 4.5 volts and the final 3.0 volts, which is 1.5 volts for the battery, or .5 volt per cell. On light current drains, a cut-off of 1.0 volt per cell is sufficiently low to insure obtaining a major portion of the total energy originally stored in the cell, whereas, if the cut-off is made 1.5 volts, which would be the case if only two cells were used, the amount of service obtainable would be very small, indeed.

On account of the extremely small current taken by the UV-199 tube, filament rheostats having much more resistance than common must be employed. If the voltage of a new dry-cell battery is 4.5 volts, the rheostat must be able to absorb 1.5 volts with a current of only 60 milliamperes flowing through it. This immediately establishes the minimum resistance necessary at 25 ohms, but in order to provide a reasonable factor of safety, and to allow for flexibility in making adjustments, a rheostat having at least 30 ohms should be used.

The greatest amount of service from the battery will be obtained by always adjusting the filament rheostat as close to the "off" position as possible, consistent with good performance. Incidentally, this method of control will also result in prolonging the life of the tube.

When so used, the filament rheostat can be looked on as a rough indicator of the condition of the battery. With new cells, it will be necessary to move the rheostat only a very short distance away from the "off" position. As the voltage of the cells is reduced through service, the handle must be moved farther and farther over to obtain good results, until finally, it must be thrown all the way over. This is an indication that the voltage of the dry cells has fallen to the voltage of the tube, and when this happens, the cells are exhausted and should be discarded and new ones installed.

The capacity of a dry cell is measured in ampere-hours, the same as a storage battery. An ampere-hour is the amount of electricity taken from a battery when a current of one ampere flows for one hour, or  $\frac{1}{4}$  ampere for four hours, or  $\frac{1}{8}$  ampere for eight hours, etc. It is always obtained by multiplying the time in hours by the current in amperes.

It is impossible to state the capacity of a dry cell, unless all the conditions under which the cell will work are known. The question, "What is the capacity of a dry cell?" is quite similar to that old one, "How high is up?" It is as easy to answer one as the other.



There are three major factors, each having an important bearing on the capacity of a dry cell, and all three are under the control of the user. They are: the cut-off voltage, the current drain, and the average number of hours the cells are used daily.

Just how can the user control these factors? Take the cut-off voltage. This, in connection with the UV-199 tube, is determined by the number of cells, connected in series, used to operate the tube. For example, the tube voltage is 3.0 volts. If two cells are used, the cut-off for the two cells is 3.0 volts, or 1.5 volts per cell. With three cells, the cut-off becomes 1.0 volt per cell, and with four cells it is  $\frac{3}{4}$  of a volt per cell. In general, the lower the cut-off voltage, the greater the capacity of the cell, but in this case, it is inadvisable to reduce the cut-off of  $\frac{3}{4}$  of a volt by using four cells, for two reasons. First, the cost of a fourth cell is a  $33\frac{1}{3}$  per cent. increase over the cost of three cells, while the extra amount of service obtained by using four cells is less than  $33\frac{1}{3}$  per cent. greater than from three cells. In other words, it is not economical. Secondly, there are no filament rheostats generally available having sufficient resistance to absorb the extra voltage of the additional cell. As far as the UV-199 tube is concerned, therefore, the cut-off becomes established at 1.0 volt per cell.

The effect of different current drains on the capacity of a dry cell is somewhat involved. In general, the smaller the current, the greater the capacity, but this is true only within certain limits. If the current taken from the cell is too small, the time required to exhaust it is so great that the factor of natural depreciation becomes active, thereby reducing the capacity. If the current is too great, the capacity is again reduced, due to the lowered battery voltage. So, in choosing a current drain for dry cells, one must be taken which is somewhere between these two extremes. It is necessary to choose between a heavy current, which discharges the cell rapidly, but reduces its capacity, and a very light drain which prolongs the time of service, but also reduces the capacity. On radio loads, where current is drawn from the cells for an average of two or more hours per day, this happy medium occurs somewhere in the neighborhood of  $\frac{1}{8}$  ampere.

The two curves shown herewith (Fig. 1) serve to illustrate how different current drains affect the capacity of a dry cell. The solid curve shows the capacity of dry cells when delivering

current two hours per day, and the dotted curve the capacity when the cells were operated four hours per day. Both curves represent the capacity of a dry cell to a cut-off of 1.0 volt, and are the average results obtained by testing a large number of different makes of cells. It is not intended that the figures given on this chart, or in the discussion of it, be taken literally as an absolute measure of the capacity of a dry cell. They are merely intended to give an approximate idea of what the average user may expect from the usual general-purpose dry cells when used to operate UV-199 tubes. Some operators will obtain greater capacity than indicated, and others will obtain less, depending on their skill and the conditions of operation.

It will be seen that in both cases, maximum capacity is obtained at a current drain of about one-eighth (.125) ampere. At smaller drains than this, the capacity falls off, due to the natural depreciation of the cell, and, as is to be expected, the decrease in capacity is greater for the cells which were in use only two hours per day, because the length of time required to exhaust them was so much greater. Thus, at a current drain of .06 ampere (the current taken by one UV-199 tube) the capacity at 2 hours per day was 21 ampere-hours, which means that the number of hours service obtained was 350. Since the cells were discharged only two hours per day, it required 175 days, or approximately six months to complete the test. In the case of the 4 hour per day cells, the capacity was 26.4 ampere-hours, which was 440 hours of service. But since these cells were in use 4 hours per day, the test only lasted 110 days, or about  $3\frac{3}{4}$  months instead of six, and it is this shorter time which explains the increase in capacity.

Although it is in the power of the user of a

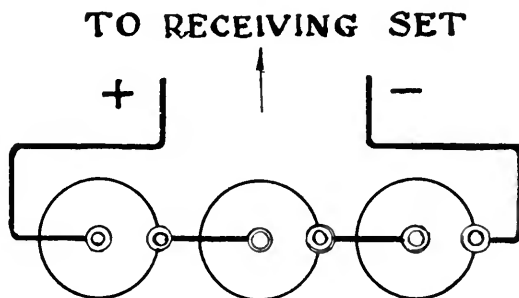

FIG. 2

Three dry cells connected in series. This is the most economical A battery for sets employing from one to three UV-199 tubes

radio set to regulate the number of hours of service each day, it is unreasonable to expect him to do it. Under certain conditions, greater capacity will be obtained from dry cells by reducing the number of hours they are in use daily, but can you imagine a radio enthusiast shutting down his set at 8:57 P. M., right in the middle of a good program, merely because by so doing he will be adding a possible 5 per cent. or 10 per cent. to the life of his A battery? It is to laugh.

The number of hours the average set is used daily is a moot question. At one time, it was generally felt that two hours a day was fairly representative of average performance. But of late, loud speakers are coming into more general use, and because of this, the amount of time put in by the average set has gone up considerably. Eventually, of course, all receiving sets will employ loud speakers. A receiving set without a loud speaker will some day be as much of a curiosity and excite as much comment as an automobile without a top. Because of the tendency toward universal loud-speaker operation, it is felt that the time the average set is used daily is closer to four hours than two. There are some individual cases known where the set is used an average of eight hours a day!

The most economical current drain on the dry cells used as an A battery can be obtained by connecting the proper number of cells in multiple. When this is done, the total drain is equally divided between the cells, so that each one delivers only a fraction of the total. In

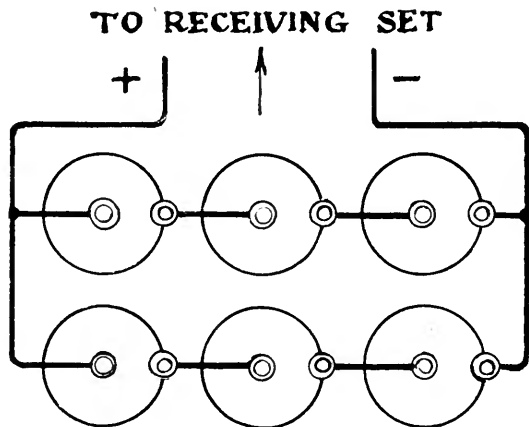

FIG. 3

From sets employing four or five tubes, maximum economy will be obtained by using six dry cells, connected three in series and two in multiple, as shown here. When flashlight cells are used, this last arrangement forms the most economical A battery for one tube

connection with UV-199's, however, the situation is somewhat complicated, because of the necessity of using three cells connected in series to obtain the correct voltage. This is not so bad as it appears, for it is only necessary to consider three cells connected in series as a battery. Then any number of such three-cell batteries may be connected in multiple to get the most economical drain on each.

The curves (Fig. 1) will be useful in determining the most economical battery for any given radio set. As an example, assume a set having three UV-199 tubes. The total drain therefore is  $3 \times .060 = .180$  amperes. Reference to Fig. 1 shows that the corresponding capacity is 23 ampere-hours when used two hours per day. If the drain is reduced by using two three-cell batteries connected in multiple, the total drain of .180 amperes is equally divided between the two batteries, so that the drain on each is only .090 amperes. But at this drain, the capacity of each battery is only 22 ampere-hours, which is less than when the drain is .180 amperes. Therefore, for sets employing one to three UV-199 tubes, the most economical "A" battery is one made up of three six-inch dry cells, connected in series (Fig. 2).

Now, take the case of a four-tube set. Here the total drain is .240 amperes, and the corresponding capacity is 19 ampere-hours. By using two three-cell batteries connected in multiple the drain on each is reduced to .120 amperes, with a corresponding capacity of 26 ampere-hours for each battery, or a combined capacity of 52 ampere-hours. This is by far the most economical battery to use, for while it requires double the number of cells, the amount of service is considerably more than doubled.

Applying the same method of calculation to different numbers of UV-199 tubes, the most economical battery is found to be as follows:

For one to three tubes, use three cells connected in series (Fig. 2).

For four or five tubes, use two three-cell batteries connected in multiple (Fig. 3).

For six or more tubes, use three three-cell batteries connected in multiple (Fig. 4).

Because of its ability to operate from an A battery made up of flashlight cells, the UV-199 lends itself admirably to the construction of small portable sets. Such a battery is much smaller and lighter than a six-inch dry cell, and, taking advantage of these properties, it is possible to design a complete receiving set,

including all the necessary batteries in a remarkably small amount of space. It should be remembered, however, that electrical energy in the form of flashlight cells is somewhat more expensive than in six-inch dry cells. Therefore, when designing a portable set, it is advisable to provide terminals to which an external A battery of six-inch dry cells may be connected. Then, when the set is to be used at home, use the large battery, and depend on flashlight batteries only when the set is to be taken away on a trip.

Only the largest size flashlight cells, which are approximately  $2\frac{1}{4}$  in. long and  $1\frac{1}{4}$  in. in diameter, should be used. They take up very little more room than the smaller sizes, but they last a great deal longer.

The current drain which gives maximum capacity for the large size flashlight cell is .030 ampere. This is one half the drain caused by one UV-199 tube, therefore, the most economical flashlight A battery is one using six cells for each tube, connected as in Fig. 3. However, a single three-cell battery will give remarkable results, considering its size. When used between one and two hours per day, such a battery of reliable manufacture will give approximately 30 hours of service, which is sufficient for most vacation trips.

Never attempt to operate more than one UV-199 tube from a battery of three flashlight cells. Use at least as many such batteries as there are tubes in the set, otherwise the current drain on the cells will be so heavy that the amount of service obtainable from them will be seriously reduced.

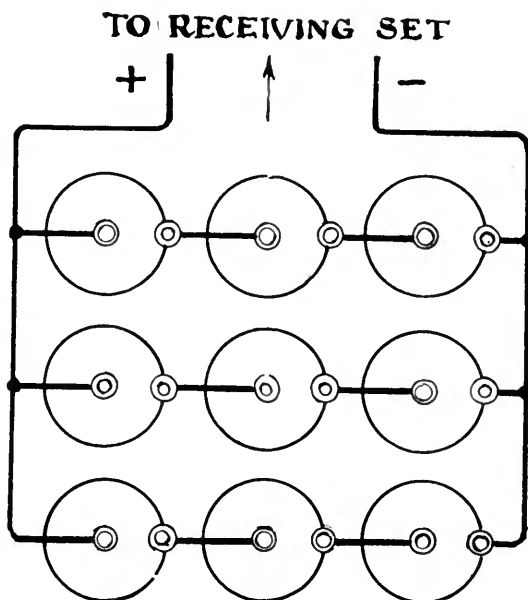

FIG. 4

When six or more UV-199's are used, it is best to employ nine dry cells connected as shown above

In planning the construction of a small portable set, the designer will naturally utilize the smallest size B battery, to conserve space and cut down weight. But for home use, it is inadvisable to depend on these tiny batteries, primarily because their capacity is extremely limited. Provision should be made for connecting a large external B battery to the set, just as in the case of the A battery. The large size B battery has many times the capacity of the small one, but costs less than twice as much.

## What Radio Holds for Boy Scouts

A Brief Outline of Some of the More Important Possibilities of Radio in Their Application to One of the Biggest and Best Games America has Ever Gone in For

By ARTHUR H. LYNCH

**A**S MOST of us know, the Boy Scout is pledged to "Do a good turn daily." Let us consider briefly some of the aspects of radio as they may be applied to Scouting to make it possible for a number of good turns to be done. One of the best troop activities I know of is the building of complete receiving sets by troops for installation in hospitals. Scout

leaders throughout the country should appreciate some of the direct benefits which will come to their troop following a campaign of this sort. First of all, it will indicate quite clearly to the citizens of the community that the particular Scout troop engaged in this work is not only interested in its own welfare but in the welfare of the community. And what better activity could any of us engage in than

doing our small part to make life more pleasant for those in hospitals?

In order to put a radio set in a hospital satisfactorily, it is generally necessary to arrange for two types of reception. As a rule a complete receiving set provided with suitable amplifiers is all that is necessary. If this outfit is of the loop variety, it may be mounted on a "tea-wagon" and wheeled about from one room to another without difficulty. If it is taken into a convalescent ward it is unlikely that a loud speaker would prove disturbing to any of the patients, but in those rooms or wards where the patients are very sick, a better arrangement is to have a telephone receiver or pair of receivers attached to a plug and placed beside each bed. In this instance, the tuning equipment would be controlled by a hospital attendant and the incoming signals would be sent through the hospital on a set of wires with plugs at each bed. Patients who desired to listen-in would then only have to place the plug attached to their telephones in the socket

to hear whatever was going on, without annoying their neighbors in any way.

In a community of any size it should not be difficult for an active Scout troop to secure an appropriation large enough to pay for the wiring if the troop itself would undertake to furnish the radio equipment, and it is likely that those who enjoy this broadcasting brought to them by the Scout troop will look with favor upon other activities that this particular troop undertakes.

#### IN THE CONTAGIOUS SICK ROOM

ANOTHER very important work that lends itself particularly to Scouting is the installation of receiving outfits in the homes of people who are quarantined because of contagious diseases. Scarlet fever, for example, is sometimes followed by serious complications, and in order to ward off complications of this nature it may be necessary for the patient to be kept in a dark, or partly dark, room. In order that the eyes may not be strained, reading



CONVALESCING HOSPITAL PATIENTS FIND RADIO A GREAT BOON

It helps to pass pleasantly the time they must lie in bed or stay indoors. A whole troop of scouts should have little difficulty in earning enough to pay for the installation and up-keep of a set such as this in the hospital in their community

is not allowed and where a contagious disease exists, the patient is not even allowed the privilege of an occasional visit from his friends. Naturally, a person who is ordinarily active and in touch with the affairs in the world, when confined to bed under conditions of this sort finds the rest particularly irksome. A radio set, in such a case, will undoubtedly win for the Scout or Scout troop that installs it the everlasting appreciation of the patient.

In making an installation of this character however, every precaution should be taken to safeguard oneself against the possible contraction of the disease, and it is not advisable for those who supply the equipment to make the installation personally because it would be possible to carry the disease to others even though they did not contract it themselves. It is always better to make an installation of this character in strict accordance with the dictates of the local Board of Health. For example, a set might best be assembled out of the sick room, and its operation explained to someone in charge of the patient.

#### IN VETERANS' HOSPITALS

**M**OST of us hear very little to-day of those war veterans who are patients in hospitals maintained by the Government, but there are a great many of them. Would it not be well for the Scouts of the country to undertake a campaign to secure radio outfits for these men? In many instances some of those in the hospitals are quite familiar with radio receiving equipment and would be able to install and operate outfits if they had them. In this way they would be able to bring entertainment to the fellows who are still confined to their cots.

*A great many radio sets have been bought that are not at present being used.* Many people who purchased crystal outfits have gradually put them aside in favor of tube sets. These crystal outfits are performing the rather useless function of collecting dust in attics or closets. The number of broadcasting stations in the country has increased so rapidly that very few veterans' hospitals are now out of range of all stations, with a crystal receiver. Receiving



#### SCOUTS LEARN TO MAKE THINGS WITH THEIR HANDS

An up-and-doing crowd of boys such as this could do a good turn, size extra large, by combining to build radio receivers for invalids

outfits would be particularly appreciated at this time of year when most of the stations in the country are broadcasting the baseball scores. Most of these men are baseball fans and follow the game as closely as they can. One of the best ways to help put some fun and diversion into the lives of these fellows is to get them to think about baseball. A radio set will help them to do it.

#### IN SCOUT CAMPS

**T**HERE are many Scout camps in this country at present, and it is more than likely that the majority of these camps will have at least one good radio outfit this summer. The large set may be used in the evening to entertain the gang and the various small sets may be used in field communication activities. Simple low-powered telephone and telegraph transmitters will make the signaling course particularly attractive this summer. A good transmitting station at camp headquarters will serve to transmit all kinds of messages to troops in the field, and maneuvers may be engaged in that would be entirely impossible otherwise. Radio as a means of signaling is very much superior to wigwagging or even wire telegraphy; and another—and perhaps the best—application of radio in camp is a course in the building of receiving equipment under the guidance of a Scoutmaster who is thoroughly capable of carrying on this work. For instance, it is well for a camp to offer as part of its curriculum, a course in simple receiver design. The experience the boys get in building their own receivers is not only helpful to them in securing a knowledge of radio but it gives them an intimate knowledge of wood-

working, soldering and the use of various tools.

That the boys of this country are interested in this sort of work is very apparent from the fact that in a single camp last year seventy-six per cent. of the boys who attended constructed

radio receiving sets—and the fun didn't end with the boys: it gave them something with which to entertain the whole family.

Radio really has something to offer Scouting. Let all Scouts make the best of it this summer.

## Radio Broadcast Central

The Radio Corporation's Station at Aeolian Hall, New York — The Dream of the Pioneer of 1903, the Vision of the Engineer of 1913, a Reality for the Betterment of Mankind in 1923

By PIERRE BOUCHERON

Director of Advertising and Publicity of the Radio Corporation of America

**A**MID the hustle and bustle of the world's greatest metropolis, a new broadcasting station has been established. It is different from any station we have seen, so far, in that it is made up of a quadruple personality, so to speak. Except for the fact that it employs but two antennas, it incorporates four complete broadcasting stations. There are,

to be sure, only two studios, but in these days of out-of-the-studio broadcasting, two are quite sufficient, and the arrangements for this sort of broadcasting made at Radio Broadcast Central are in keeping with the great advance marked by the station itself.

For instance, a permanent group of wire lines has been run along Sixth Avenue for several miles, beginning at 14th Street. There

are permanent lines from this central cable to the Town Hall, the Waldorf Astoria Hotel and Aeolian Hall. By running short, temporary lines to theatres or other important gathering places, it is possible to supply the radio audience with the best of music, drama, humor, lectures, religious services, and the like that New York can furnish. In opening Radio Broadcast Central, Mr. Owen D. Young, Chairman of the Board of the Radio Corporation of America, summed up this phase of the enterprise in the following words:

"Broadcasting has appealed to the imagination as no other scientific development of the time. Its ultimate effect upon the educational, social, political, and religious life of our

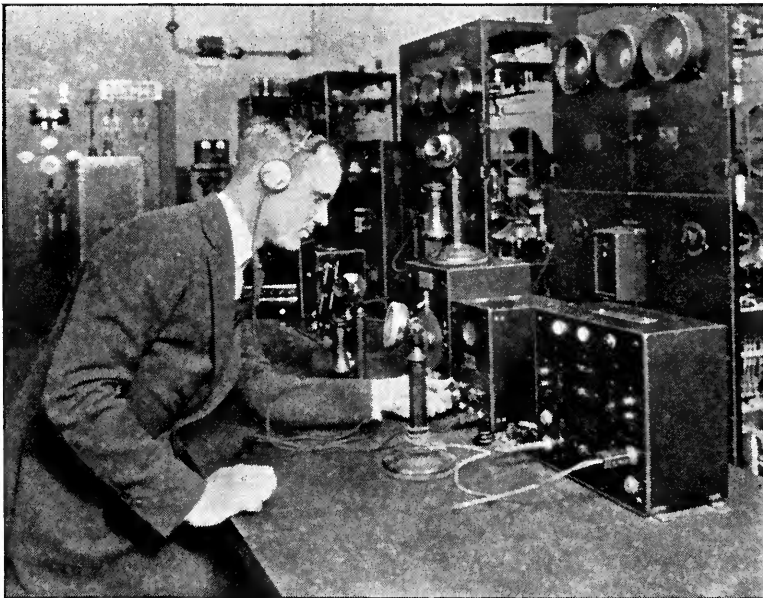

WHEN A TUBE "BLOWS"

It is necessary for the operator in the operating room on the roof merely to cut out the transmitter thus crippled and switch in another. There are two separate broadcasting "channels," one for WJZ and one for WJY, and each channel is equipped with two transmitters. Besides the operating crew, there is a man constantly listening-in for vessels in distress. If he hears an SOS, the broadcasting is immediately suspended

country and of the world is quite beyond our ability to prophesy.

"Already it is bringing to the farmer, market, weather, and crop reports as well as time signals, which cannot help but be of economic value: in remote communities, where the country parson is no longer in attendance at Sunday morning services, it is filling a great need in the spiritual life; its educational possibilities are being investigated by our foremost national and state educators; it is taking entertainment from large centres to individual homes; to the blind and sick it has unfolded a new and richer life. For the purpose of communication it has destroyed time and space."

There are two stations at Radio Broadcast Central, which may be operated simultaneously or individually. WJZ is the 455-meter station, used to broadcast music and entertainment of the lighter kind, while WJY, operated on 405 meters, is used for broadcasting opera, classical music, and lectures on more serious subjects.

At Aeolian Hall, where this super-station is located, WJZ and WJY are characterized as channels A and B respectively, and each is equipped with two complete sets of equipment in order to prevent any break in the program being broadcasted, regardless of any mechanical trouble that may develop. There are two pick-up devices in each studio, as well as a system of dual wiring from the studio to the control station on the roof where two complete transmitters are used on each channel.

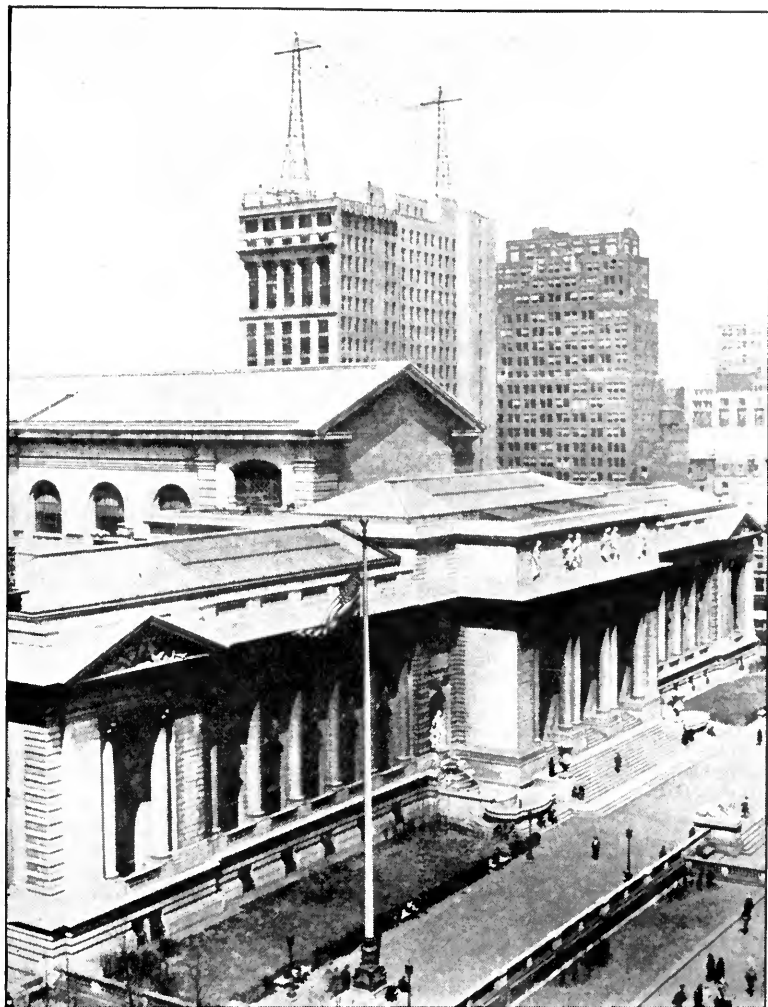

AEOLIAN HALL, NEW YORK

From 40th Street, with the Public Library in the Foreground

The broadcasting from Aeolian Hall is already recognized as being of the highest character. In dedicating the station to the people of America, General Harbord, President of the Radio Corporation, said: "This station will gather from every part of New York City and from all available sources all that will instruct and entertain, and hurl it over millions of square miles of territory." It is, as the General expressed it, "the world's first national theatre."



# The Grid

## QUESTIONS AND ANSWERS

The Grid is a Question and Answer Department maintained especially for the radio amateurs. Full answers will be given wherever possible. In answering questions, those of a like nature will be grouped together and answered by one article. Every effort will be made to keep the answers simple and direct, yet fully self-explanatory. Questions should be addressed to Editor, "The Grid," RADIO BROADCAST, Garden City, N. Y.

### AUDIO AMPLIFYING CIRCUITS

*I have a two-step receiver of my own construction, using Cunningham detector and two Cunningham amplifiers.*

*This arrangement is not giving satisfaction, and I should appreciate your publishing what you consider to be the best amplifying hook-up.*

—E. E. B., Itta Bene, Miss.

**A**UDIO-FREQUENCY amplification has become so standardized that the various transformer coupled hook-ups have resolved themselves into a single-conventional circuit, which may be applied to any receiving set. This fact is at variance with the impression under which many of our readers labor, that different receiving circuits require different systems of audio-frequency amplification.

Figure 1 shows the usual circuit for a two-step amplifier. The three telephone jacks make it possible to plug in at the detector, first or second stage. The last jack (J<sub>2</sub>) may be an open-circuit jack, as in the diagram, or a closed-circuit one similar to J<sub>d</sub> and J<sub>1</sub>, the inner contacts running to binding posts for a loud-speaker. Thus, when the plug is removed (the headset eliminated) the loud-speaker is automatically thrown into the circuit.

No amplifier will operate properly on poor tubes or transformers, nor will satisfactory amplification be secured on a plate voltage under sixty. The bulb should be a hard one, i. e., there should be no blue or purple haze about the elements when the plate voltage is applied and the filament lighted. The amplifying transformers should be of a reliable manufacture, and the experimenter is advised to expend from four to seven dollars in procuring them, rather than purchase transformers of doubtful value for half that price.

The transformers should be mounted with at least four

inches between cores, and many experimenters make a practice of placing the transformers with the cores at right angles to each other. Careful separating of instruments and wiring in amplifying circuits eliminates feed-back with resulting howls and squeals.

Rheostats of the wire or compression types, vernier or otherwise, may be used. The 1½ volt tubes are also adaptable to amplification circuits, and will give very good results when used in conjunction with transformers designed to balance their impedance.

The only restrictions on panel layout are those concurrent with adequate spacing, and the experimenter may build the amplifier so that it will conform in appearance with his present apparatus. However, before constructing the set, it is suggested that the builder familiarize himself with the interior details of some standard manufactured amplifier.

Connections should be well soldered, using soldering paste rather than acid or rosin, and all superfluous flux should be wiped away, washing the joints if necessary with wood alcohol. This precaution is particularly important on the lugs of the jacks, where messy soldering will result in annoying clicks and extraneous sounds.

Such an amplifying installation (Fig. 1) may be added to any receiving set by disconnecting the telephone receivers, and replacing them by the primary of the first stage, amplifying transformer (input). Condenser C, indicated in the diagram, is a telephone shunt condenser of .002 mfd. capacity. It is possible that such a condenser is already included in the experimenter's present receiving equipment, in which case the extra capacity will not be necessary.

### MULTI-LAYER COILS AND INDUCTION

*Can you tell me what size honeycomb DL coils, according to catalogue numbers, are best for receiving broadcasts on 360*

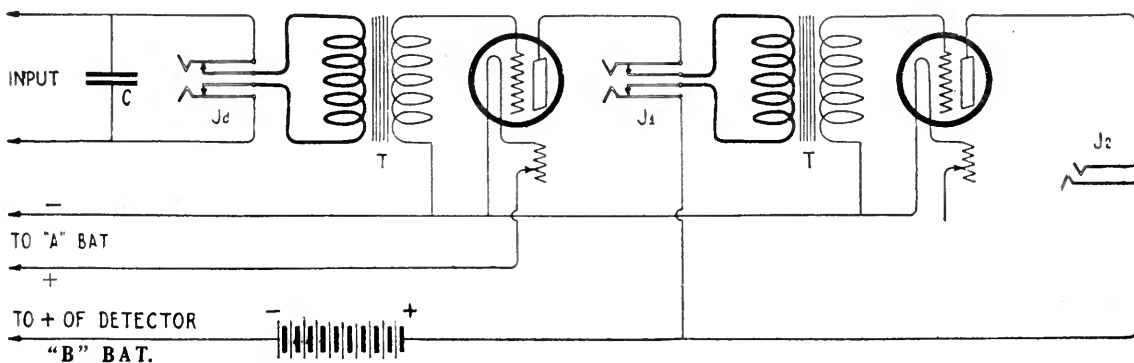
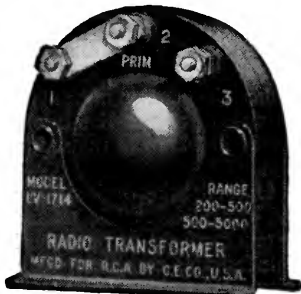

FIG. 1

The usual circuit for a two-step amplifier. The lead from the second amplifier rheostat should, of course, go to "+ A"



# Get Long Range with RCA radio- frequency transformers



Model UV-1714  
\$6.50

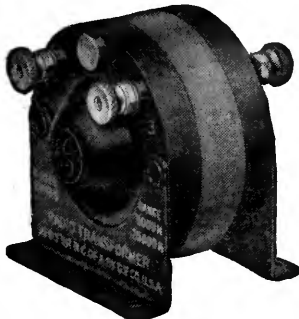

Model UV-1716  
\$8.50

- To make a small inside loop reach as far as an outside antenna.
- To increase tremendously the range of an outdoor aerial without distortion.
- To amplify singly or in cascade; complete shielding prevents interaction of fields.

—To cover a broad band of wave lengths and pick up stations of every class.

*Particularly Adapted for Use  
with RCA Radiotron Tubes*

Insist on RCA audio and radio-frequency transformers at your dealer



*This symbol of quality  
is your protection*

★  
**Radio**  **Corporation**  
of America

Sales Dept., Suite 2066  
233 Broadway  
New York, N. Y.

District Sales Offices  
10 South LaSalle Street, Chicago, Ill.  
433 California Street, San Francisco, Cal.

★ Tested and approved by RADIO BROADCAST ★

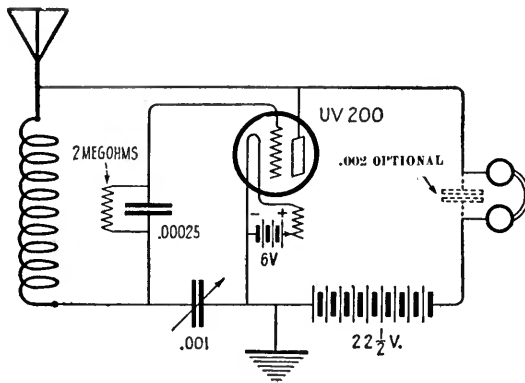

FIG. 2  
The "Flivver" Circuit

and 400 meters, i. e., the sizes to use in primary, secondary, and tickler? What do the numbers mean?

I would also like to know what causes the humming noise in my receivers when I am using two steps of audio-frequency amplification. It sounds like a generator hum, and it is present over the entire tuning range of the set.

L. T., CINCINNATI, OHIO.

THE DL35, DL50, and DL75 are the correct sizes for broadcast reception, primary, secondary, and tickler being respectively indicated.

On the original honeycomb coils, the numerals referred to the number of turns of wire wound on the designated coil. Thus, an L50 was wound with fifty turns of wire. However, a slightly different method of winding was shortly discovered, which resulted in coils superior to the original honeycombs; and it was found that the number of turns on the new coils, called the Duolateral or DL, necessary to secure a certain value of inductance, differed from the number of turns required by the honeycomb for the same effect. The numeral following the initials "DL" indicates that the duolateral coil may be substituted for a honeycomb coil of that number of turns.

The humming heard in the telephone receivers is probably due to induction from near-by electric light wires. A reading lamp on the operating table is often sufficient to give rise to such a disturbance, and usually the trouble can be remedied by merely moving the lamp farther from the instruments, particularly from the detector and amplifying cabinet. If ordinary care is taken to keep unnecessary electric light wires away from the apparatus, and to run those essential to its operation in armored cable, the hum will be eliminated.

However, if our correspondent is using a single-circuit tuner, it is possible that the sound is induced from the street lines to his antenna. If such is the case, an inductively coupled tuner will rectify matters.

#### FARM LIGHTING PLANTS AND RADIO

I am located on a farm which is equipped with a 32-volt lighting plant. Can this be used in any way for radio reception?

B. O. Z., BOUCK'S FALLS, N. Y.

A FARM lighting plant can be used very nicely for the lighting of receiving filaments, it being only necessary to include sufficient resistance in the circuit to drop the voltage and protect the tubes.

A series of 6- or 10-ohm porcelain-base rheostats is a convenient resistance for this purpose. Using a single tube drawing one ampere, such as the UV-200 and UV-201, a variable resistance with a maximum of 30 ohms will be sufficient to drop the 32 volts to the working potential of the bulb. However, if the WD-11, 201-A or a similar quarter-ampere tube is used, the resistance must be considerably higher, using not less than 125 ohms for a single bulb.

If two tubes are to be used constantly, the external resistance may be halved, and if three tubes, it may be lowered two thirds the total resistance given for a single tube. This is due to the fact that the voltage drop is directly proportional to the current consumed. Therefore, all tubes must be turned off by a common switch, and the circuit through amplifying filaments never broken until the resistance is increased to the required value for the remaining detector bulb.

In all cases where bulbs are lighted from a comparatively high voltage dropped through a common resistance, each tube should be separately fused, in order to protect the remaining bulbs when the filament of one burns out in the course of time. Unless this precaution is taken, the sound tubes will necessarily be blown in the sudden rise of the applied voltage.

In some types of farm lighting equipment one side of the line will be found grounded. While this will not affect reception with certain receivers, on the majority of circuits it will result in undesirable complications and probably decrease selectivity. When this ground is not effected through the frame of the engine and the exhaust pipe, it is easily eliminated by removing the ground wire.

#### THE "FLIVVER SET"

Will you please give me the circuit of the so-called "Flivver Set"? I am anxious to construct this apparatus which I understand is a very simple and excellent regenerative receiver.

The required parts are, I believe, 43-plate condenser (variable), 1 Duolateral coil of fifty turns, detector tube, etc.

R. W. W., WILKES BARRE, PA.

THE accompanying diagram (Fig. 2) indicates the connections for the "Flivver Set." The single tube "super" is also called the "flivver."

However, RADIO BROADCAST does not recommend the use of this circuit in its unmodified form in other than isolated radio districts. The flivver system, which oscillates almost continually during the process of tuning, is nothing more than the Colpitts transmitting circuit used extensively in continuous-wave transmission. Even when employed as a receiver, with a soft tube and low plate voltage, it is capable of radiating an interfering wave which may be often picked up with annoying consequences over a mile away. Out of consideration for other listeners this circuit, as shown, should never be used in cities or even small towns.

However, in such congested localities, the undesirable radiation may be eliminated by the addition of one step of tuned-plate radio-frequency amplification. There are several excellent sets, using this system, on the market. However, when this pound of cure is resorted to, the total expense of the apparatus, which is now a two-bulb set, and the complexity of the installation are such that the original purchase or building of a selective three-circuit tuner is recommended as preferable.



Any Good  
Receiving Set

Magnavox keeps the "stay-at-homes" happy

THE "boys" just naturally make their headquarters in proximity to the receiving set whose owner has been wise enough to add a Magnavox Reproducer and Power Amplifier. When "Magnavox invites you." the Radio party is sure to be a success.

Magnavox R2 Reproducer and 2 stage Power Amplifier (as illustrated) \$115.00

R2 Magnavox Reproducer with 18-inch horn: the utmost in amplifying power; requires only .6 of an ampere for the field . . . . . \$60.00

R3 Magnavox Reproducer with 14-inch curvex horn: ideal for homes, offices, etc. . . . . \$35.00

Model C Magnavox Power Amplifier insures getting the largest possible power input for your Magnavox Reproducer  
2 stage \$55.00  
3 stage 75.00

Magnavox Products can be had from good dealers everywhere. Write for new booklet.

THE MAGNAVOX COMPANY  
Oakland, California  
New York Office: 370 Seventh Avenue

# MAGNAVOX PRODUCTS

No Radio Receiving Set is complete without them



7-R

★ Tested and approved by RADIO BROADCAST ★

# Supplemental List of Broadcasting Stations in the United States

LICENSED FROM APRIL 21 TO MAY 17 INCLUSIVE

CALL SIGNAL	STATION	FREQUENCY (Kilocycles)	WAVE-LENGTH
KFEX	Augsburg Seminary, Minneapolis, Minn.	1150	261
KFGC	Louisiana State University, Baton Rouge, La.	1180	254
KFGJ	138th Inf., National Guards, St. Louis, Mo.	1130	266
KFGM	Abilene Daily Reporter, Abilene, Texas	1290	233
KFGP	Cheney Radio Co., Cheney, Kans.	1310	229
KFGQ	Crary Hardware Co., Boone, Iowa	1330	226
KFGV	Heidbreder Radio Supply Co., Utica, Nebr.	1340	224
KFGX	First Presbyterian Church, Orange, Tex.	1200	250
KFGY	Gjelhaug's Radio Shop, Baudette, Minn.	1340	224
KFGZ	Emmanuel Missionary College, Berrien Springs, Mich.	1120	268
KFFX	The McGraw Co., Omaha, Nebr.	1080	278
KFHC	University of Oklahoma, Norman, Okla.	1180	254
KFHD	Utz Electric Co., St. Joseph, Mo.	1330	226
KFHF	Central Christian Church, Shreveport, La.	1130	266
KFHI	Chas. V. Dixon, Wichita, Kans.	1340	224
KFHL	Penn College, Oskaloosa, Iowa	1320	227
KFIB	Franklin W. Jenkins, St. Louis, Mo.	1230	244
KFIC	Philip Laskowitz, Denver, Colo.	1340	224
KFID	Ross Arbuckle's Garage, Iola, Kans.	1220	246
KFIQ	Yakima Valley Radio Broadcasting Assn., Yakima, Wash.	1240	224
WABC	Fulwider-Grimes Battery Co., Anderson, Ind.	1310	229
WABD	Parker High School, Dayton, Ohio	1060	283
WABE	Y. M. C. A., Washington, D. C.	1060	283
WABF	Mt. Vernon Register-News Co., Mt. Vernon, Ill.	1280	234
WABG	Arnold Edwards Piano Co., Jacksonville, Fla.	1210	248
WABH	Lake Shore Tire Co., Sandusky, Ohio	1250	240
WBBA	Newark Radio Club, Newark, Ohio	1250	240
WBBC	Sterling Radio Equipment Co., Sterling, Ill.	1310	229
WCBB	K & K Radio Supply Co., Greenville, Ohio	1250	240

## DELETIONS FROM MARCH 19 TO APRIL 30

KDYB	Salt Lake City, Utah	WEAC	Terre Haute, Ind.
KDYY	Denver, Colo.	WEAE	Blacksburg, Va.
KDZA	Tucson, Ariz.	WEAW	Anderson, Ind.
KDZL	Ogden, Utah	WFAD	Salina, Kans.
KDZM	Centralia, Wash.	WFAS	Fort Wayne, Ind.
KDZZ	Everett, Wash.	WFAY	Independence, Kans.
KFAS	Reno, Nev.	WGAB	Houston, Tex.
KFBV	Colorado Springs, Colo.	WGAK	Macon, Ga.
KFCC	Wallace, Idaho	WGAT	Lincoln, Nebr.
KFGG	Astoria, Oreg.	WIAZ	Miami, Fla.
KHD	Colorado Springs, Colo.	WLAM	Springfield, Ohio
KLP	Los Altos, Calif.	WMB	Auburn, Me.
KOG	Los Angeles, Calif.	WNAK	Manhattan, Kans.
KON	San Diego, Calif.	WNO	Jersey City, N. J.
KOP	Hood River, Oreg.	WPAQ	Portsmouth, Va.
KXS	Los Angeles, Calif.	WOAY	Birmingham, Ala.
KZC	Seattle, Wash.	WOZ	Richmond, Ind.
KZI	Los Angeles, Calif.	WPAV	Laurium, Mich.
WAH	El Dorado, Kans.	WPAX	Thomasville, Ga.
WBAG	Bridgeport, Pa.	WRAJ	Pittsburgh, Pa.
WCAP	Decatur, Ill.	WSAS	Lincoln, Nebr.

## What Would You Like to Have in Radio Broadcast?

The editors would be pleased to hear from readers of the magazine on the following (or other) topics:

1. The kind of article, or diagram, or explanation, or improvement you would like to see in RADIO BROADCAST.
2. What has interested you most, and what least, in the numbers you have read so far.